

C 60 Hz



Centrifugal Pumps with open impeller
Bombas centrifugas con rodete abierto



Coverage chart - Campo de aplicaciones

n ≈ 3450 rpm

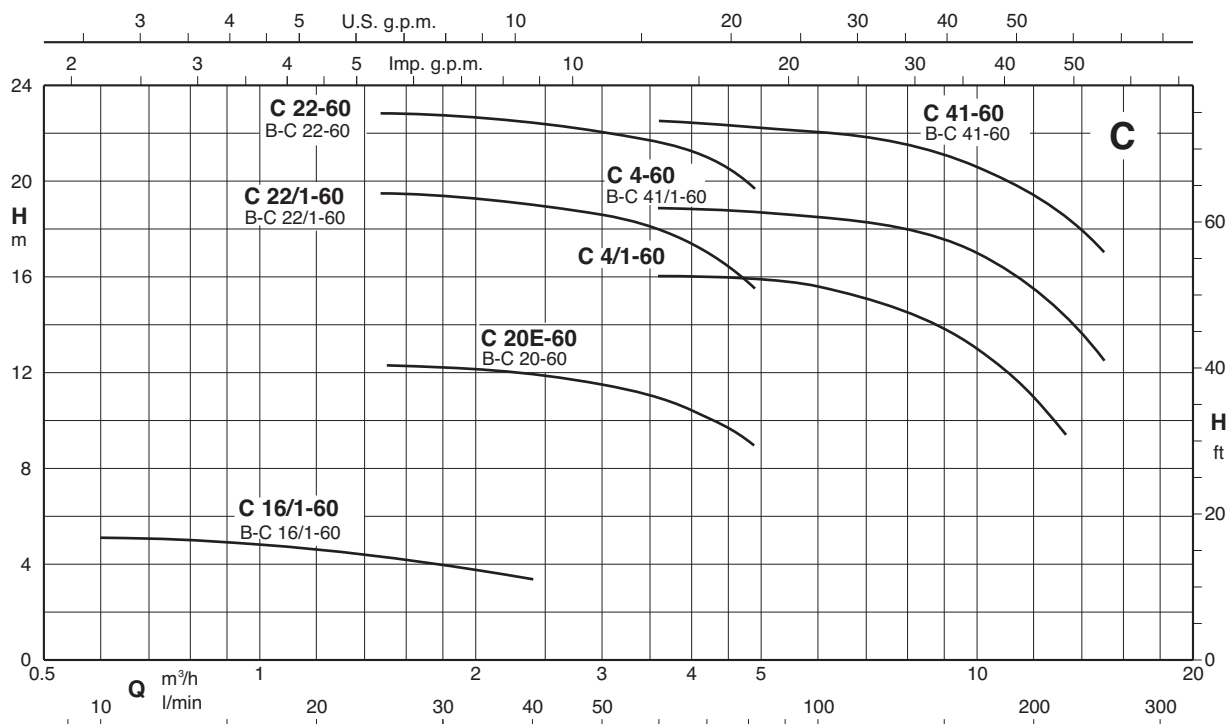

Construction

Close-coupled centrifugal pumps with open impeller.
Free-flow impeller (vortex or recessed impeller) for type C 16/1E.
Connections: threaded ports **ISO 228/1**.
threaded ports **NPT** (ANSI/ASME B1.20.1) on request

C: version with pump casing and lantern bracket in cast iron.
B-C: version with pump casing and lantern bracket in bronze
(the pumps are supplied fully painted).

Applications

For moderately dirty liquids or emulsions.
For industry and agriculture.

Operating conditions

Liquid temperature from -10 °C to +90 °C.
Ambient temperature up to 40 °C.
Total suction lift up to 8 m.
Maximum permissible working pressure: 6 bar.
Maximum size of solids: 4 mm.
Continuous duty.

Motor

2-pole induction motor, 60 Hz (n ≈ 3450 rpm).
C: three-phase 220/380 V, 220/440 V,
CM: single-phase 110 V, 127 V, 220 V.
with thermal protector up to 1.1 kW only 220V.
Capacitor inside the terminal box.
Insulation class F.
Protection IP 54.
Motor suitable for operation with frequency converter from 1,1 kW.
Classification scheme IE3 for three-phase motors from 0,75 kW.
Constructed in accordance with: EN 60034-1; EN 60034-30-1.
EN 60335-1, EN 60335-2-41.

Special features on request

- Other voltages.
- Protection IP 55.
- Special mechanical seal
- Higher or lower liquid or ambient temperatures.
- Motor suitable for operation with frequency converter up to 0,75 kW.

Materials

Component	C	B-C
Pump casing	Cast iron GJL 200 EN 1561	Bronze G-Cu Sn 10 EN 1982
Lantern bracket	Cast iron GJL 200 EN 1561	Bronze G-Cu Sn 10 EN 1982
Impeller	Brass P- Cu Zn 40 Pb 2 UNI 5705	
Shaft	Chrome steel 1.4104 EN 10088 AISI 430	Cr-Ni-Mo steel 1.4401 EN 10088 (AISI 316)
	Cr-Ni steel 1.4305 EN 10088 (AISI 303) for C 41E	
Mechanical seal	Carbon - Ceramic - NBR	

Ejecución

Electrobomba centrífuga monobloc con rodete abierto.
Rodete tipo vortex para tipo C 16/1E.
Orificios: Roscados **ISO 228/1**.
Roscados **NPT** (ANSI/ASME B1.20.1) bajo demanda.

C: Ejecución con cuerpo bomba y acoplamiento in hierro.
B-C: Ejecución con cuerpo bomba y acoplamiento in bronce.
Las bombas en bronce se suministran totalmente pintadas.

Aplicaciones

Para líquidos moderadamente cargados de impurezas o emulsionados.
Para la industria y la agricultura.

Límites de empleo

Temperatura líquido de - 10 °C a + 90 °C.
Temperatura ambiente hasta 40° C.
Altura de aspiración manométrica hasta 8 m.
Presión máxima admitida en el cuerpo de la bomba 6 bar.
Máximo diámetro cuerpos solidos: 4 mm.
Servicio continuo.

Motor

Motor a inducción 2 polos, 60 Hz (n = 3450 1/min).
C: trifásico 220/380 V, 220/440 V.
CM: monofásico 110 V, 127 V, 220 V.
con protector térmico hasta 1,1 kW sólo para 220V.
Condensador incorporado en la caja de bornes.
Aislamiento clase F.
Protección IP 54.
Motor preparado al funcionamiento con convertidor de frecuencia de 1,1 kW.
Clase alta eficiencia IE3 para motor trifásico de 0,75 kW.
Ejecución según EN 60034-1; EN 60034-30-1.
EN 60335-1, EN 60335-2-41.

Otras ejecuciones bajo demanda

- Otras tensiones.
- Protección IP 55.
- Sello mecánico especial.
- Para líquidos o ambientes con temperaturas más elevadas o más bajas.
- Motor preparado al funcionamiento con convertidor de frecuencia hasta 0,75 kW.

Materiales

Componentes	C	B-C
Cuerpo bomba	Hierro GJL 200 EN 1561	Bronce G-Cu Sn 10 EN 1982
Acoplamiento	Hierro GJL 200 EN 1561	Bronce G-Cu Sn 10 EN 1982
Rodete	Latón P- Cu Zn 40 Pb 2 UNI 5705	
Eje	Acero al cromo 1.4104 EN 10088 (AISI 430)	Acero al Cr-Ni-Mo 1.4401 EN 10088 (AISI 316)
	Acero al cromo-níquel 1.4305 EN 10088 (AISI 303) para C 41E	
Sello mecánico	Carbón - Cerámica - NBR	

Performance - Prestaciones

n ≈ 3450 rpm

3 ~	1 ~	P ₂		Q m ³ /h l/min	H m																
		kW	HP		0,6	0,9	1,2	1,5	1,8	2,4	3	3,6	4,8	6	6,6	8,4	9,6	10,8	12	13,2	15
C 16/1E-60 B- C 16/1E-60	CM 16/1E-60 B- CM 16/1E-60	0,15	0,2		5	4,7	4,4	4,2	4	3,3											
C 20E-60 B- C 20-60/A	CM 20E-60 B- CM 20-60/A	0,37	0,5					12,3	12,2	12	11,5	10,8	9								
C 22/1E-60 B- C 22/1-60/A	CM 22/1E-60 B- CM 22/1-60/A	0,45	0,6					19,5	19,4	19,1	18,7	17,9	15,3								
C 22E-60 B- C 22-60/A	CM 22E-60 B- CM 22-60/A	0,55	0,75					22,5	22,5	22,4	22	21,5	19,5								
C 4/1-60/A	CM 4/1-60/A	0,55	0,75									16	15,8	15,5	15,1	14,3	13,5	12,2	11	9,5	
C 4-60/B B- C 41/1E-60	CM 4-60/A B- CM 41/1E-60	0,75	1									19	18,8	18,5	18,3	17,7	17,2	16,5	15,5	14,4	12,5
C 41-60/A B- C 41-60/A	CM 41E-60 B- CM 41E-60	1,1	1,5									22,6	22,3	22,1	22	21,5	21	20,3	19,5	18,5	17

B-C, B-CM = Bronze construction.
Ejecución en bronce.

P₂ Rated motor power output.
Potencia nominal del motor.

H Total head in m.
Altura total en m.

Tolerances according to UNI EN ISO 9906:2012.
Tolerancias según UNI EN ISO 9906:2012.

ρ = Density 1000 kg/m³.
Densidad 1000 kg/m³.

ν = Kinematic viscosity max 20 mm²/sec.
Viscosidad cinemática max 20 mm²/sec.

Features - Características constructivas

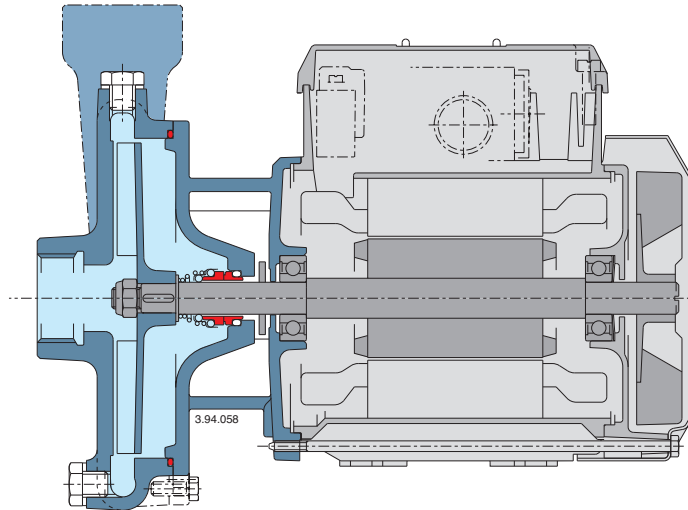

Flexibility

The option to choose between cast iron and bronze materials for the hydraulic parts in contact with the pumped liquid allows C series pumps to be selected for use with different types of liquids.

Solid parts

The open impeller allows for the passage of suspended solids in pumped liquid.

Reliability

The bearing and shaft are designed to ensure the reduction of the stress, providing high reliability under all operating conditions.

Flexibilidad

La opción de poder elegir entre hierro fundido y bronce para las partes hidráulicas en contacto con el bombeo permite que las bombas de la serie C puedan ser seleccionadas para utilizar con diferentes tipos de líquidos.

Partes sólidas

El rodete abierto permite el paso de sólidos en suspensión en el líquido bombeado.

Fiabilidad

El cojinete y el eje están diseñados para asegurar la reducción de la tensión, proporcionando alta fiabilidad en todas las condiciones de funcionamiento.

Rated currents - Intensidades nominales

TYPE TIPO	P ₂		single-phase - monofásico			
	kW	HP	220V IN A	127V IN A	110V IN A	IA/IN
CM 20E-60	0,15	0,2	1,5	2,6	3	2,7
	0,37	0,5	3,1	5,4	6,2	2,5
CM 22/1E-60	0,37	0,5	3,4	5,9	6,8	2,3
	0,45	0,6	4,1	7,1	8,2	2,5
CM 22E-60	0,45	0,6	4,3	7,4	8,6	2,6
	0,55	0,75	5,2	9	10,4	3,1
CM 4-60/A	0,75	1	6,9	12	13,8	2,9
	0,75	1	6,5	11,3	13	2,9
	1,1	1,5	8,5	14,7	-	3

TYPE TIPO	P ₂		three-phase - trifásico		
	kW	HP	220/380V IN A	220/440V IN A	IA/IN
C 20E-60	0,15	0,2	2/1,2	2,2/1,3	4
	0,37	0,5	2,3/1,3	2,4/1,4	3,5
C 22/1E-60	0,37	0,5	2,6/1,5	2,7/1,6	3,5
	0,45	0,6	3/1,7	3,1/1,8	3,8
C 22E-60	0,45	0,6	2,6/1,5	2,7/1,6	3,5
	0,55	0,75	3,5/2	3,6/2,1	4,5
C 4-60/A	0,55	0,75	3,6/2,1	3,8/2,2	3,7
	0,75	1	4,5/2,6	4,7/2,7	5,6
	0,75	1	4/2,3	4,2/2,4	7,3
	1,1	1,5	5,7/3,3	6/3,5	5,4

P₂ Rated motor power output.
Potencia nominal del motor.

IA/IN D.O.L. starting current / Rated current
Intensidad de arranque / Intensidad nominal

Dimensions and weights - Dimensiones y pesos

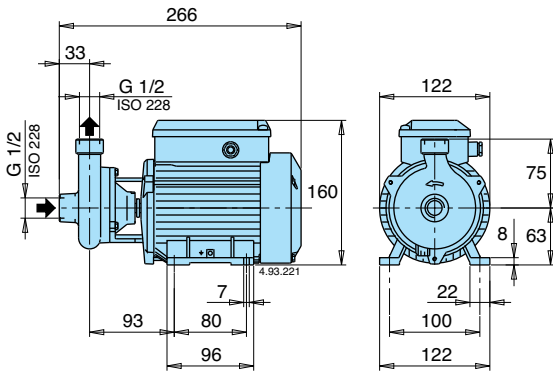

TYPE TIPO	kg
C 16/1E-60	5,2
CM 16/1E-60	5,2

TYPE TIPO	kg
B-C 16/1E-60	5,6
B-CM 16/1E-60	5,6

DN NPT Version on demand - Ejecuciones bajo demanda

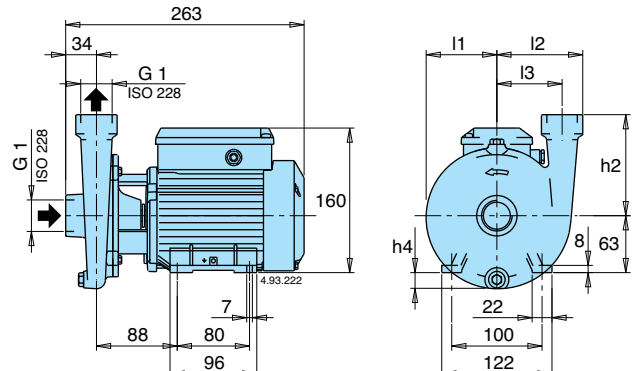

TYPE TIPO	mm					kg	
	h2	h4	l1	l2	l3	C	CM
C 20E-60	90	5	67	82	60	6,8	6,8
C 22/1E-60 - C 22E-60	110	17	77	94	71	8 - 8,3	8 - 8,3

DN NPT Version on demand - Ejecuciones bajo demanda

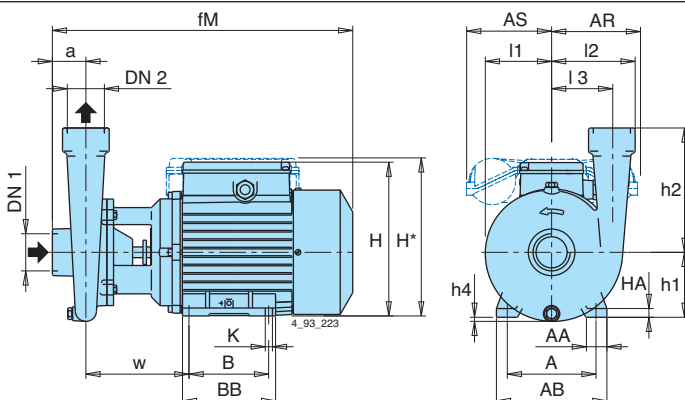

TYPE TIPO	H*	AS mm			
		220V	127V	110V	110/220V
CM 4-60/A	187	●	116	116	□

TYPE TIPO	H*	AR mm			
		220V	127V	110V	110/220V
B-C 41/1E-60	213	●	116	131	□
B-C 41E-60, C 41E-60	213	●	131	□	□

● Standard dimensions - Dimensiones estándar
□ Cannot be constructed - Non fatibles

TYPE TIPO	DN1 ISO 228	DN2 ISO 228	DN NPT	mm																kg				
				a	fM	h1	h2	H	h4	BB	B	AB	A	AA	K	l1	l2	l3	w	HA	C	CM	B-C	B-CM
- B-C 20-60/A	G 1	G 1	✓	35	303	71	90	182	-	106	90	134	112	22	7	70	84	60	105	10	-	-	9,1	9,1
- B-C 22/1-60/A	G 1	G 1	✓	35	303	71	110	182	9	106	90	134	112	22	7	81	93	71	106	10	-	-	9,3	10,3
- B-C 22-60/A	G 1	G 1	✓	35	303	71	110	182	9	106	90	134	112	22	7	81	93	71	106	10	-	-	9,6	10,6
C 4/1-60/A	G 1 1/2	G 1 1/2	✓	43	304	71	160	182	18	106	90	134	112	22	7	85	108	78	100	10	10,8	11,8	-	-
C 4-60/B	G 1 1/2	G 1 1/2	✓	43	304	71	160	182	18	106	90	134	112	22	7	85	108	78	100	10	12,6	12,8	-	-
- B-C 41/1E-60	G 1 1/2	G 1 1/2	✓	43	380	80	160	208	9	125	100	155	125	30	9,5	85	108	78	132	10	-	-	16,3	17,9
C 41-60/A - B-C 41-60/A	G 1 1/2	G 1 1/2	✓	43	380	80	160	208	9	125	100	155	125	30	9,5	85	108	78	132	10	18,5	19,3	19,2	20,1

✓ NPT Version on demand - Ejecuciones bajo demanda

Characteristic curves - Curvas Características

n ≈ 3450 rpm

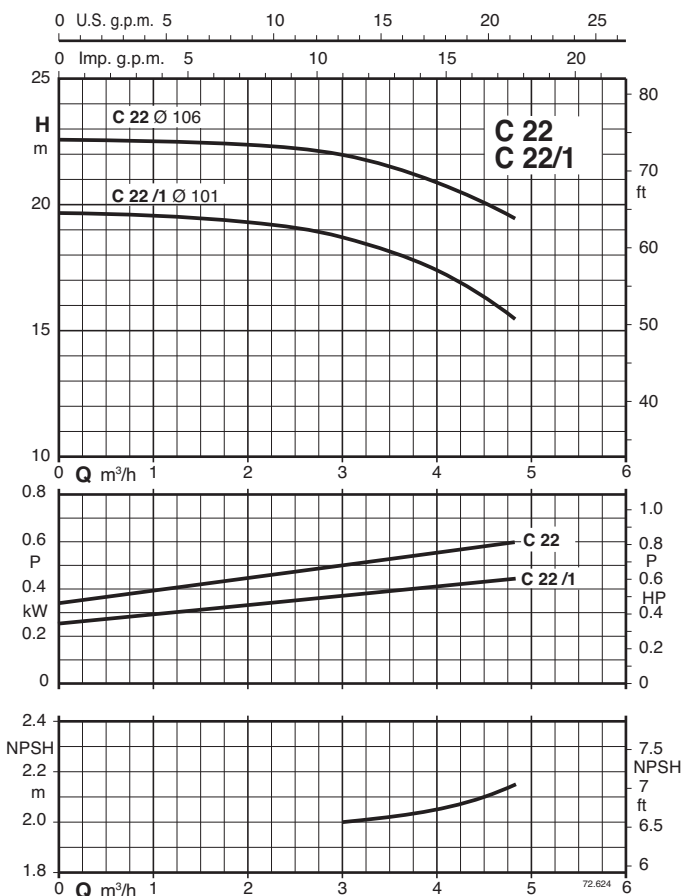
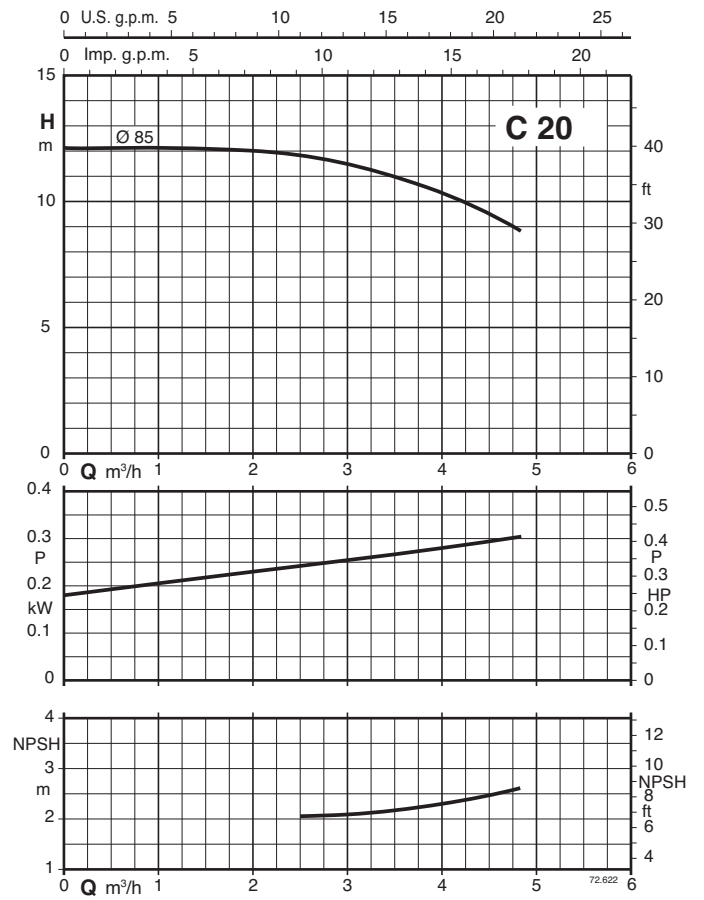
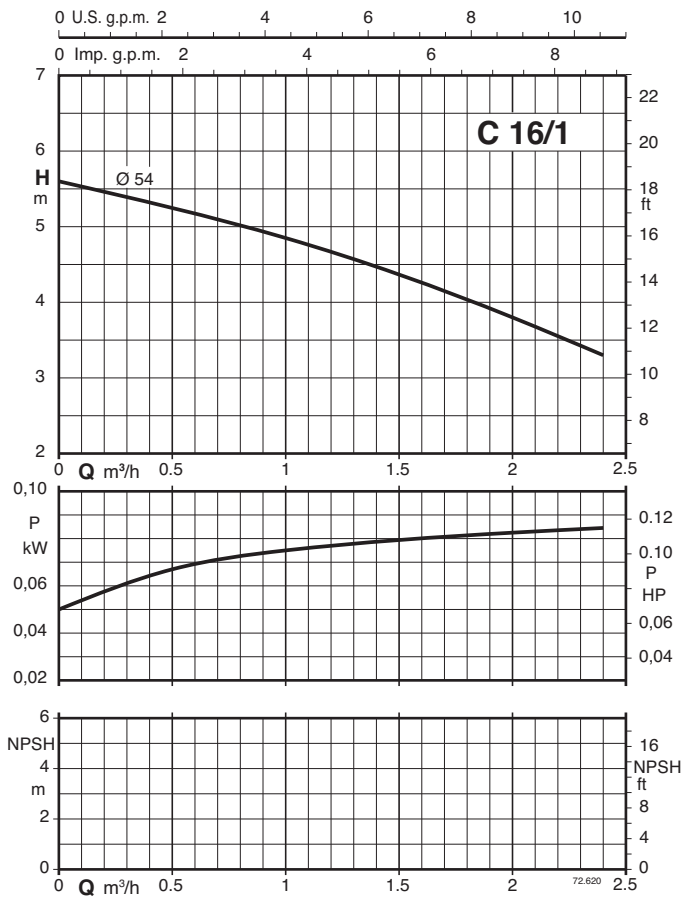

Characteristic curves - Curvas Características

n ≈ 3450 rpm

