

Flange a collarino a saldare di testa UNI EN 1092-1 PN25

(EX UNI 2283-67 PN25)

TIPO 11B

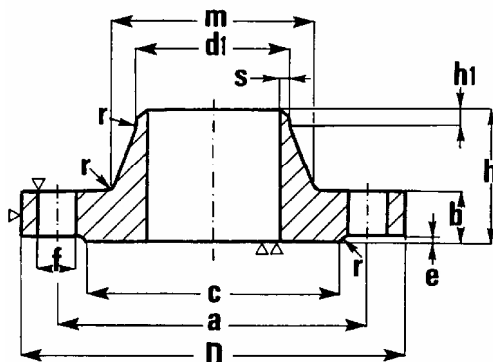

DN	Ø TUBO	d ₁	D	a	m	c	h	b	h ₁	e	r	s	f	VITI	N° FORI	Kg
	ISO	ISO			ISO											
10	17,2	18	90	60	28	40	35	16	6	2	4	1,8	14	M12	4	0,5
15	21,3	22,5	95	65	32	45	38	16	6	2	4	2,0	14	M12	4	1,0
20	26,9	28	105	75	40	58	40	18	6	2	4	2,3	14	M12	4	1,0
25	33,7	34,5	115	85	46	68	40	18	6	2	4	2,6	14	M12	4	1,0
32	42,4	43,5	140	100	56	78	42	18	6	2	6	2,6	18	M16	4	2,0
40	48,3	49,5	150	110	64	88	45	18	7	3	6	2,6	18	M16	4	2,0
50	60,3	61,5	165	125	75	102	48	20	8	3	6	2,9	18	M16	4	3,0
65	76,1	77	185	145	90	122	52	22	10	3	6	2,9	18	M16	8	4,0
80	88,9	90	200	160	105	138	58	24	12	3	8	3,2	18	M16	8	5,0
100	114,3	115,5	235	190	134	162	65	24	12	3	8	3,6	22	M20	8	6,5
125	139,7	141	270	220	162	188	68	26	12	3	8	4,0	26	M24	8	9,0
150	168,3	170,5	300	250	192	218	75	28	12	3	10	4,5	26	M24	8	11,5
200	219,1	221	360	310	244	278	80	32	16	3	10	6,3	26	M24	12	17,0
250	273	275	425	370	298	335	88	35	18	3	12	7,1	30	M27	12	24,0
300	323,9	326	485	430	352	395	92	38	18	4	12	8,0	30	M27	16	31,5
350	355,6	357,5	555	490	398	450	100	42	20	4	12	8,0	33	M30	16	48,0
400	406,4	408,5	620	550	452	505	110	46	20	4	12	8,8	36	M33	16	63,0
450	457,2	459	670	600	500	555	110	50	20	4	12	8,8	36	M33	20	75,5
500	508	510	730	660	558	615	125	56	20	4	12	10,0	36	M33	20	96,5
600	609,6	611,5	845	770	660	720	125	68	20	5	12	11,0	39	M36	20	138,6
700	711,2	715	960	875	760	820	125		20	5	12	12,5	42	M39	24	143,5
800	812,8	817	1085	990	865	930	135		22	5	12	14,0	48	M45	24	193,5
900	914,4	918	1185	1090	968	1030	145		24	5	12	16,0	48	M45	28	237,0
1000	1016	1020	1320	1210	1070	1140	155		24	5	16	17,5	56	M52	28	310,5