



# Technical Data Sheet Type 37



2/2-way solenoid valve  
 NC - Valve normally closed (as standard)  
 NO - Valve normally open (as option)

Force-pilot operated piston design valve. No differential pressure is necessary for operation. In standard (NC) the valve closes with spring power.

■ Solenoid valve for gaseous and liquid media

Type 37

## TECHNICAL SPECIFICATIONS

Type of control	Force-pilot operated, no pressure difference necessary
Design	Piston design
Connection	Flanges acc. to EN 1092-1 Form B1/B2 Other flange connections like ASME on request
Installation	With actuator upright
Pressure	0-40 bar (see table page 2)
Medium	Clean, neutral, liquid or gaseous media
max. viscosity	22 mm <sup>2</sup> /s
Temperature range	Medium: -40 °C bis +80 °C Ambient: -40 °C bis +50 °C In consideration of the restrictions described on page 4
Body material	Cast iron EN-GJL-250 Cast steel GP240 GH Stainless steel 1.4581
Metallic inner parts	Brass and stainless steel
Sealing	PTFE
Supply voltage	AC~ 24V, 110V, 230V DC= 12V, 24V Other supply voltages on request
Voltage tolerance	-10% / +10%
Power consumption	.802 = 24 Watt    .808 = 24 Watt ☺ .322 = 30 Watt    .328 = 24 Watt ☺ .242 = 46 Watt    .248 = 30 Watt ☺ .272 = 100Watt    .278 = 47 Watt ☺
Protection class	IP65 nach DIN 60529
Duty factor	100% ED-VDE 0580
Connection type	Plug, Terminal box
Ex-proof	acc. to 2014/34/EU (ATEX) Further Ex-proof on request

## VALVE FEATURES

- No pressure difference required
- High life time
- Simple compact valve design
- Reliable and sturdy sealing elements
- Long-term availability of spare parts

## FUNCTION

NC – non energized closed    NO – non-energized open

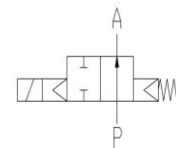
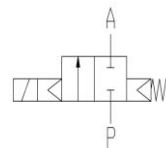

## CERTIFICATES



Special design for extended temperature ranges  
**-60 °C up to +300 °C** available.  
 Specification and drawings on request

## ORDERING SYSTEM

Type	Conn.	Housing	Seal	Coil	Option
. 3 7 0 1 /		0 4 0 4 /		. 8 0 2 -	H A
01 DN15 02 DN20 03 DN25 04 DN32 05 DN40 06 DN50		04 EN-GJL-2450 05 GP240 GH 08 St. steel 1.4581	04 PTFE	2 Standard IP65 8 Explosion proof acc. to directive 2014/34/EU (ATEX)	

# TECHNICAL FEATURES

DN	Seat mm	Kv-value m <sup>3</sup> /h	Standardtype	max. pressure with coil							
				.802	.808	.322 *	.328 *	.242	.248	.272	.278
15	15	5,0	.3701/..04/	0-40	0-30	0-40	0-40	-	-	-	-
20	20	11,0	.3702/..04/	0-16	0-16	0-40	0-25	0-40	0-40	-	-
25	25	13,0	.3703/..04/	0-16	0-16	0-40	0-25	0-40	0-40	-	-
32	32	24,0	.3704/..04/	-	-	0-25	0-16	0-40	0-25	0-40	0-40
40	40	27,0	.3705/..04/	-	-	0-25	0-16	0-40	0-25	0-40	0-40
50	50	42,0	.3706/..04/	-	-	0-6	0-2	0-16	0-10	0-40	0-16

The mentioned Kv-values are valid for the more stronger solenoid  
 Max. pressure 16 bar with EN-GJL-250 body PN16.

\* Pressure ratings with options like manual override or position indicator may be lower.

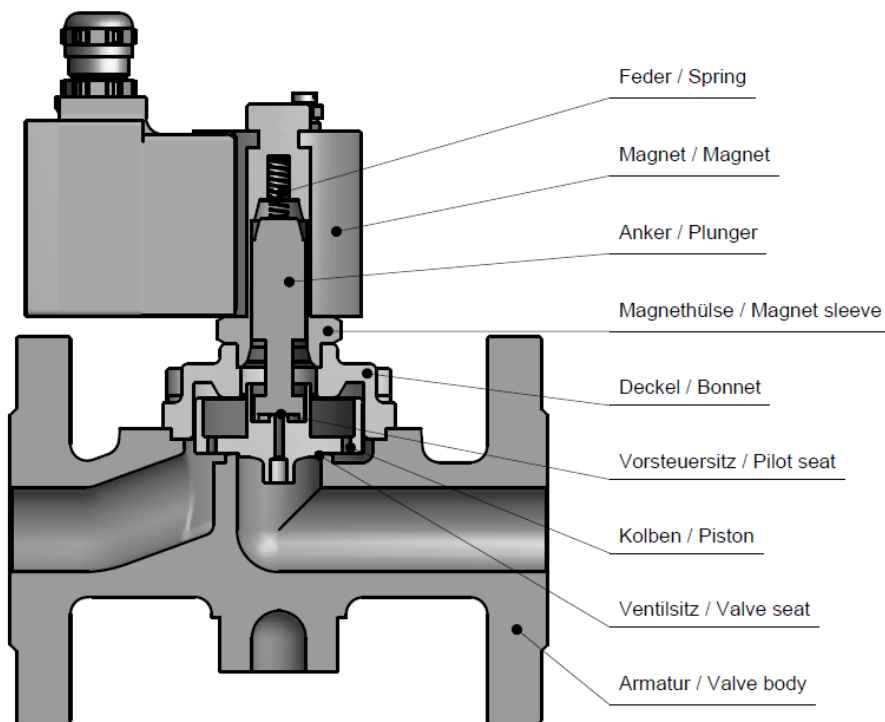

## DIMENSIONS

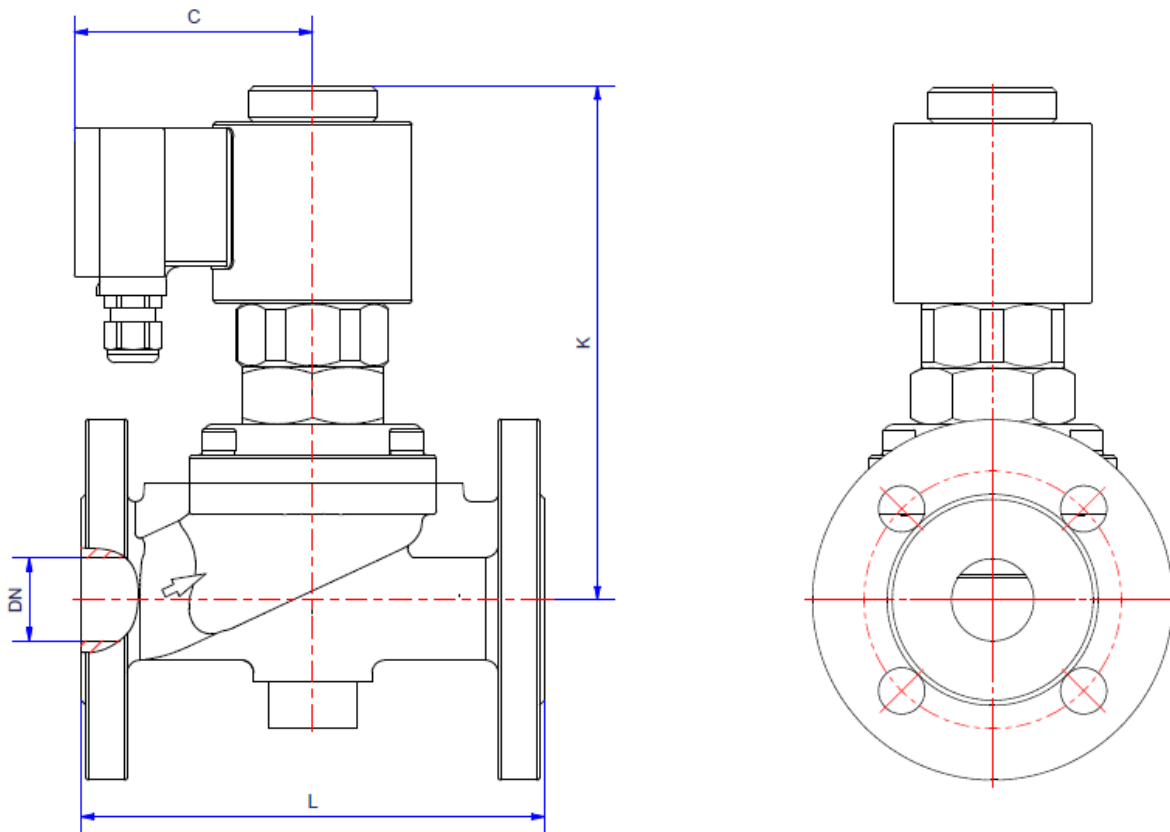

Coil	.802/.808*			.322/.328*					.242/.248			.272/.278		
Type	3701	3702	3703	3702	3703	3704	3705	3706	3704	3705	3706	3704	3705	3706
DN	15	20	25	20	25	32	40	50	32	40	50	32	40	50
C	66	66	66	76	76	76	76	76	93	93	93	105	105	105
K	104	128	128	181	181	156	156	165	200	200	200	250	250	260
L	130	150	160	150	160	180	200	230	180	200	230	180	200	230
kg	5,0	5,5	6,0	5,5	6,0	7,5	7,5	9,5	8,5	9,0	11,5	10,5	11,0	13,5

\*Different dimension "C" with ATEX-coils

## INFORMATION

- It is imperative to observe the installation and safety instructions in our operating and service manuals.
- For information on our GSR ordering code, please refer to our catalogs. If you have any questions, we will be glad to assist you.
- Required ordering information: valve type, function NC/NO, pressure range, connection, nominal width, medium, flow rate, medium and ambient temperatures, connection voltage.
- **Detailed production-specific drawings and other technical information will be made available when an order is placed**

## PLEASE NOTE

Each individual application decides which valve type is required, the main factor being the resistance of the materials to the operating medium. The correct selection of materials requires knowledge of the concentration, temperature and degree of contamination of the medium. Other criteria include the operating pressure and max. volumetric flow, since, in addition to high temperatures, high pressures and high flow rates must also be taken into account when selecting the materials.

**All materials used for our valves, be it housing, seals or magnets, will be carefully selected in view of the different application areas. Any information given is non-binding and serves for orientation only. No claims under warranty can be derived therefrom.**

## Heating and power of solenoid coils

The GSR default solenoid valves are designed for continuous operation (100% ED = power-on time) under normal operating conditions. The pulling force of a solenoid coil is basically influenced by three elements:

- The self-heating of the magnetic coil
- The medium temperature
- The ambient temperature

GSR solenoid coils are by default designed for a maximum ambient temperature of +35 °C. This specification applies for the maximum allowable operating pressure specified in the data sheet of the corresponding valve, 100% duty cycle and a medium temperature of +80 °C.

A higher ambient temperature is possible, when lower values are applied for the other influencing parameters. When the max. operation pressure and max. ambient temperature of +50 °C is given the medium temperature is not allowed to be higher than max. +50 °C. In addition to that, deviations from the default design temperature range are possible, e.g. when temperature coils or other constructive measures are used. Please contact the GSR headquarters to discuss the specific application.

More precise specifications and technical data with regard to the operating conditions can be found in the data sheets of the solenoid coils and the solenoid valve regarded. Please observe that the surface temperature of a permanently loaded coil can amount up to +120 °C, solely by the self-heating of the coil. The power consumption of our default solenoid valves was calculated to DIN VDE 05820 for a coil temperature of +20 °C.

- The GSR logo is a registered trademark of GSR Ventiltechnik GmbH & Co. KG.
- Note: All texts and images are the property of GSR Ventiltechnik GmbH & Co. KG and must not be replicated or modified, not even in part, without written approval.
- Original products may differ from the product images shown, due to different materials and the like.
- Subject to error and changes.

**Stand: 05.18, MK-MG, Version 1**