



Materials

Components	Materials
Pump casing	Cast iron GJL 200 EN 1561
Gears	Steel 18 Ni Cr Mo 5 UNI 8550
Shafts	Steel 18 Ni Cr Mo 5 UNI 8550
Radial shaft seal ring	FPM

Construction

Close-coupled gear pumps (rotary pumps).
Pump casing with suction and delivery connections with the same diameter and on the same axis (in-line execution).

Applications

For fuel oil and liquids with lubricating properties.

Operating conditions

Kinematic viscosity from 30 mm²/s (4 °E) to 120 mm²/s (15°E).
Liquid temperature up to 90 °C.
Ambient temperature up to 40 °C.
Total suction lift up to 4 m.
Continuous duty.

Motor

4-pole induction motor, 60 Hz (n ≈ 1750 rpm).

I, IR, IRR: three-phase 220/380 V.

IM : single-phase 220 V.

Insulation class F.

Protection IP 54.

Constructed in accordance with: EN 60034-1; EN 60034-30.
EN 60335-1, EN 60335-2-41.

Special features on request

- Other voltages.
- Protection IP 55.
- Higher liquid or ambient temperatures.

Performances n ≈ 1750 rpm

	3 ~ 220V 380V		1 ~ 220V P ₁		P ₂		n rpm	Q m ³ /h l/min	Δp bar	0.72
	A	A	A	kW	kW	HP				12
I	25/4-60/A	1,7	1	IM 25/4-60/A	2,5	0,48	0,25	0,34	1750	2
IR	25/4-60/A	2,4	1,4				0,37	0,5	1750	2.5
IRR	25/4-60/A	3,8	2,2				0,75	1	1750	5

P₁ Max. power input.

P₂ Rated motor power output.

Δp Differential pressure.

Dimensions and weights

I 25/4-60/A
IM 25/4-60/A
IR 25/4-60/A

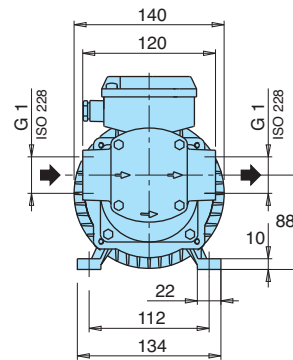
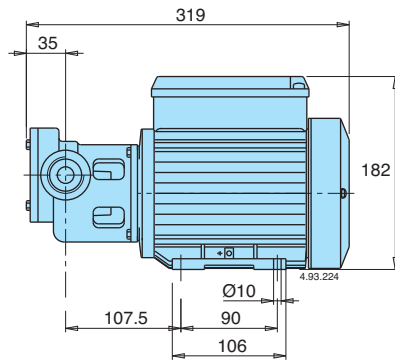

TYPE	kg
I 25/4-60/A	10
IM 25/4-60/A	11,7
IR 25/4-60/A	11,6

IRR 25/4-60/A

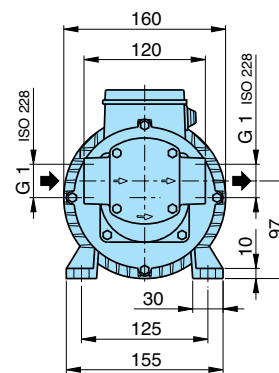
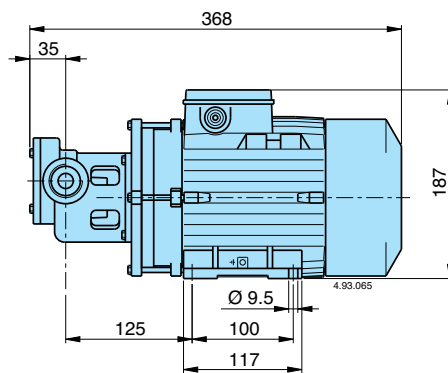

TYPE	kg
IRR 25/4-60/A	17,6

Features

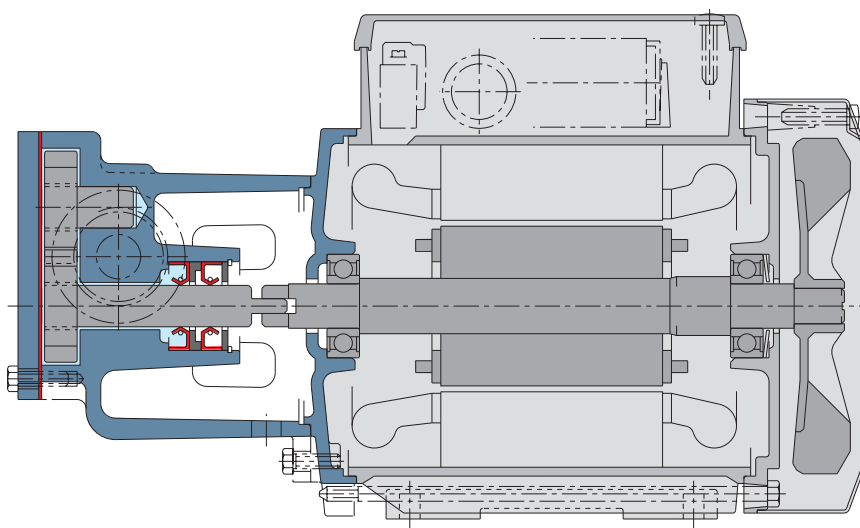

Innovative structure

The flanged pump casing and two piece shaft allows the hydraulics to be disassembled easier, facilitating quick maintenance operations.