



Controllers / Transmitters

SERIES 80



Installation and Maintenance Instructions

INDEX

1. INSTALLATION
2. CONNECTIONS
3. OPERATION
4. MAINTENANCE
5. TROUBLE CHART: SYMPTOM, CAUSE AND ACTION TO TAKE
6. CONTROLLER CLEANING
7. MEASURE ELEMENT ZERO SETTING
8. CALIBRATION
9. SPARE
10. OVERALL DIMENSIONS
11. TECHNICAL DATA

In case of mounting or operation problems, please contact our Local Agent or Service Department,

**OMC S.p.A. - Via Galileo Galilei, 18 - 20060
Cassina de Pecchi (MI) - ITALY**

Tel.: (+39) 02.95.28.468 - Fax: (+39) 02.95.21.495 - info@omcvalves.com

1. INSTALLATION

The Series 80 instruments are equipped with four standard legs for direct panel or wall mounting. Particular attention must be paid to the selection of the mounting site, to protect the equipment from exposure to vibrations, corrosive vapors, moisture, or ambient temperatures exceeding the recommended limits.

1.1 PANEL MOUNTING

Insert the instrument housing into an opening made in the panel (Fig. 1.1.1) and fasten it in place by means of the four legs and the corresponding adapter plates (Fig. 1.1.2).

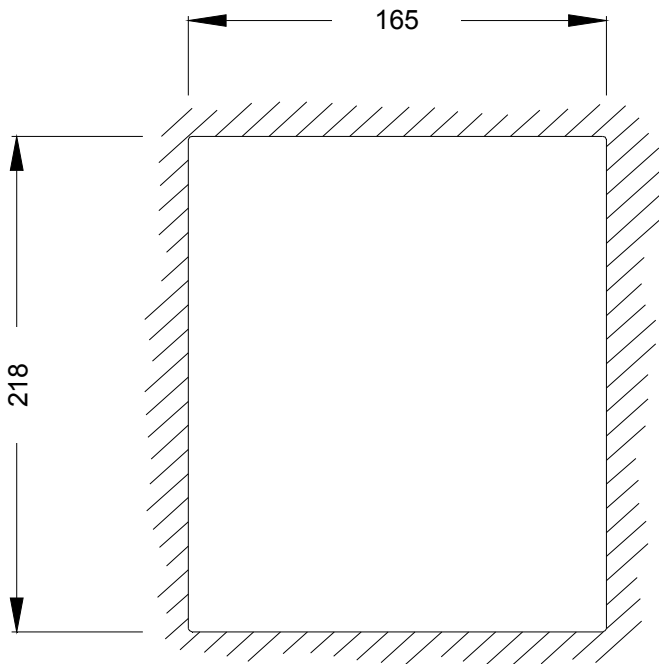

Fig. 1.1.1 "PANEL DRILLING"

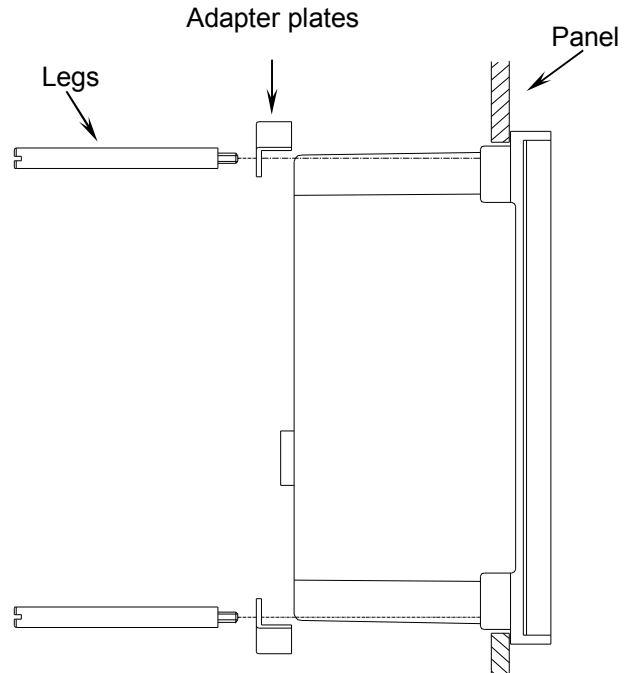

Fig. 1.1.2 "PANEL MOUNTING"

1.2 WALL MOUNTING

Wall mounting requires the installation of two metal brackets provided with legs for wall mounting. The instrument housing is fastened to the panel by screwing four M6 screws into the threaded holes in the legs (Fig. 1.2.2). The center distances of the threaded holes in the mounting legs are shown in Fig.1.2.1.

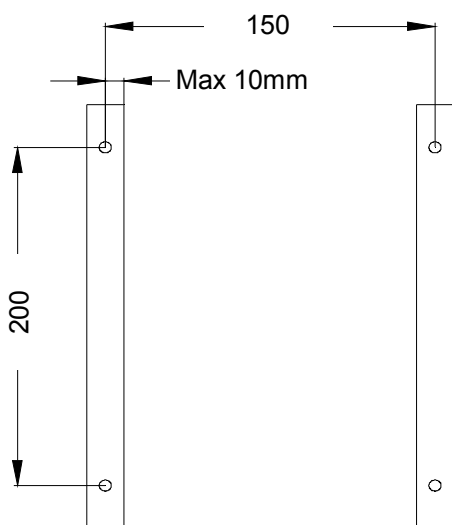

Fig. 1.2.1 "LEGS CENTER DISTANCES"

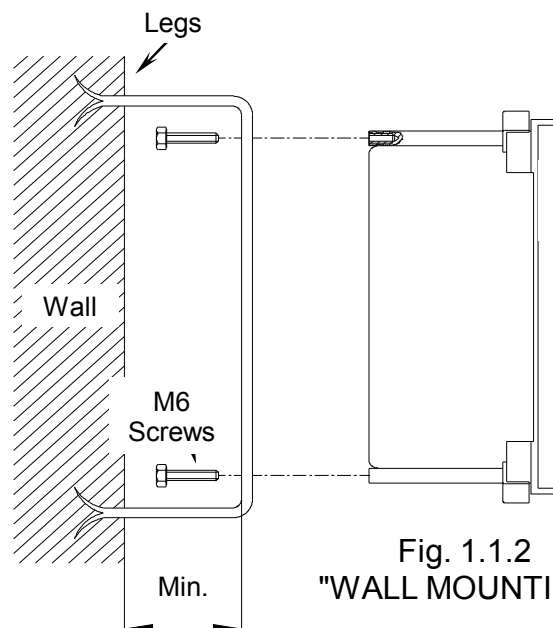

Fig. 1.1.2 "WALL MOUNTING"

2. CONNECTIONS

2.1. COMPRESSED AIR SUPPLY (Fig. 2.1.1)

The pneumatic connections (1/4"NPT) are located in the back-housing and are identified by "SUPP" (air supply input) and "OUT" (control signal output). The pneumatic instrumentation operation depends on the purity of the air supply. A filter, generally an integrated filter, must be installed in the air pressure relief system upstream to each instrument. To prevent rusting, use only pneumatic connections in non-ferrous material (copper, nylon or polyethylene). The horizontal supply line should run towards the instrument with a minimal 2% slope. The connection of the supply line to the compressed air manifold must be made in the upper part of the tubing to keep condensate from entering the instrument. If necessary, a moisture trap can be installed upstream to the filter to remove any water or oil in the air supply. For a correct operation of the pressure reducer filter, the minimal air pressure must be set at 2.8 - 3 bar. We advise against the indiscriminate use of a single reducer supplying many instruments, since abrupt variations in air consumption, due to the simultaneous operation of several instruments, might adversely affect the operation of each control unit.

N.B. For Controllers equipped with Auto/Manual Panel see paragraph 2.3

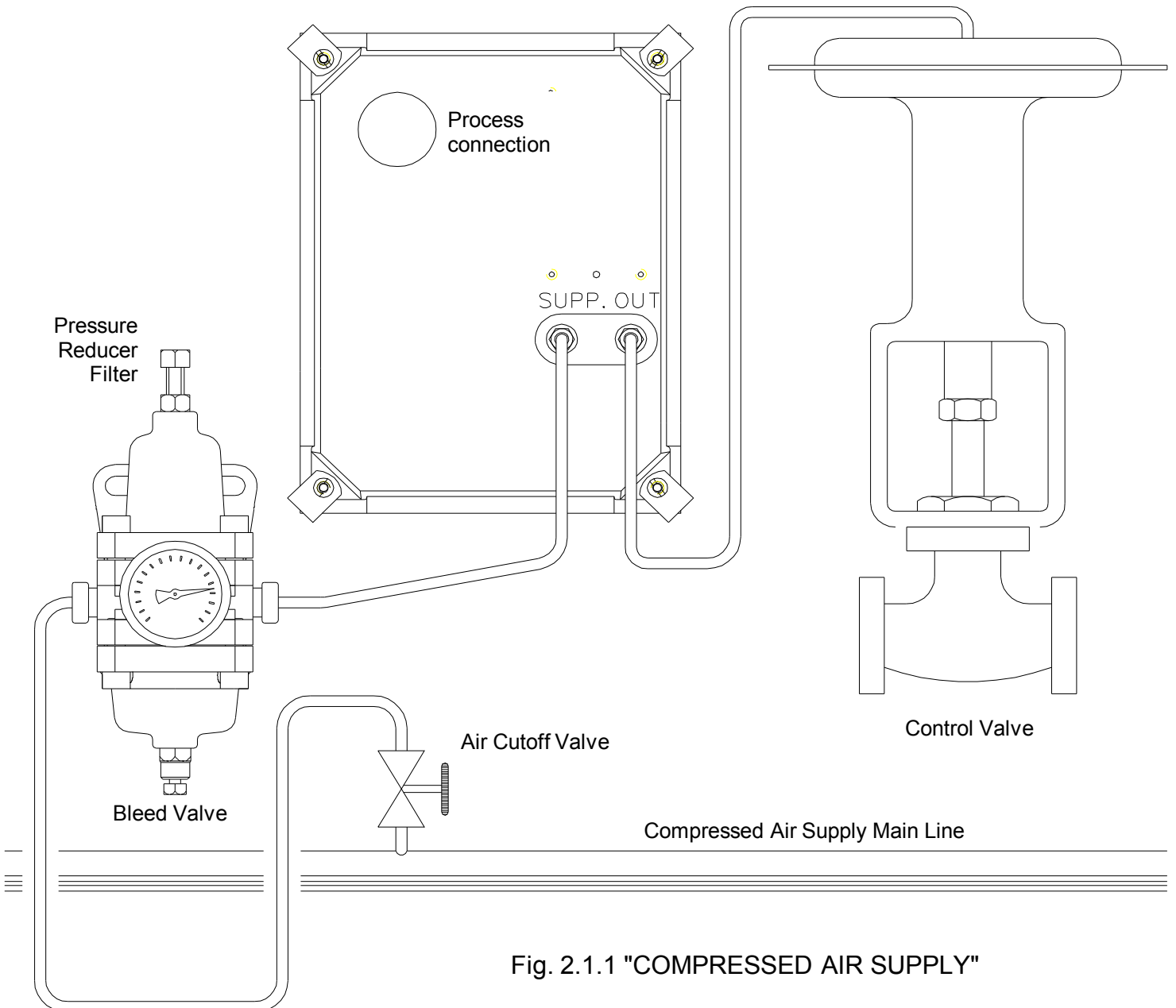

Fig. 2.1.1 "COMPRESSED AIR SUPPLY"

2.2. PNEUMATIC CONTROL VALVE INSTALLATION (Fig. 2.2.1)

The control output from the controllers has a standard value of 3 ± 15 psi (0.2 ± 1 bar). The signal must be transmitted to the pneumatic control valve via a 4x6 copper or nylon tube. Make sure that the pneumatic connection line is completely air-tight, since any leak of air, though minimal, would change the characteristic of the control action. We recommend checking the line for leaks by spraying all joints and connections with soapy water. Before installing the pneumatic valve, make sure that the tubing conveying the process fluid is clean by blowing a strong blast of steam or compressed air into the tubing, when possible. The installation of a filter upstream to the valve will prevent the dirt from entering the throttling element. In order to perform a periodic maintenance on valves mounted in non-stop operating systems, we advise installing two upstream and downstream cutoff valves and one bypass valve. The bypass valve can be used to manually control the process when the control valve is temporarily disconnected. The cutoff valves should have an internal diameter equal to that of the control valve, which will facilitate manual control operations. When installing the pneumatic valve, make certain that the fluid in the tubing flows in the direction shown by the arrow located on the valve body.

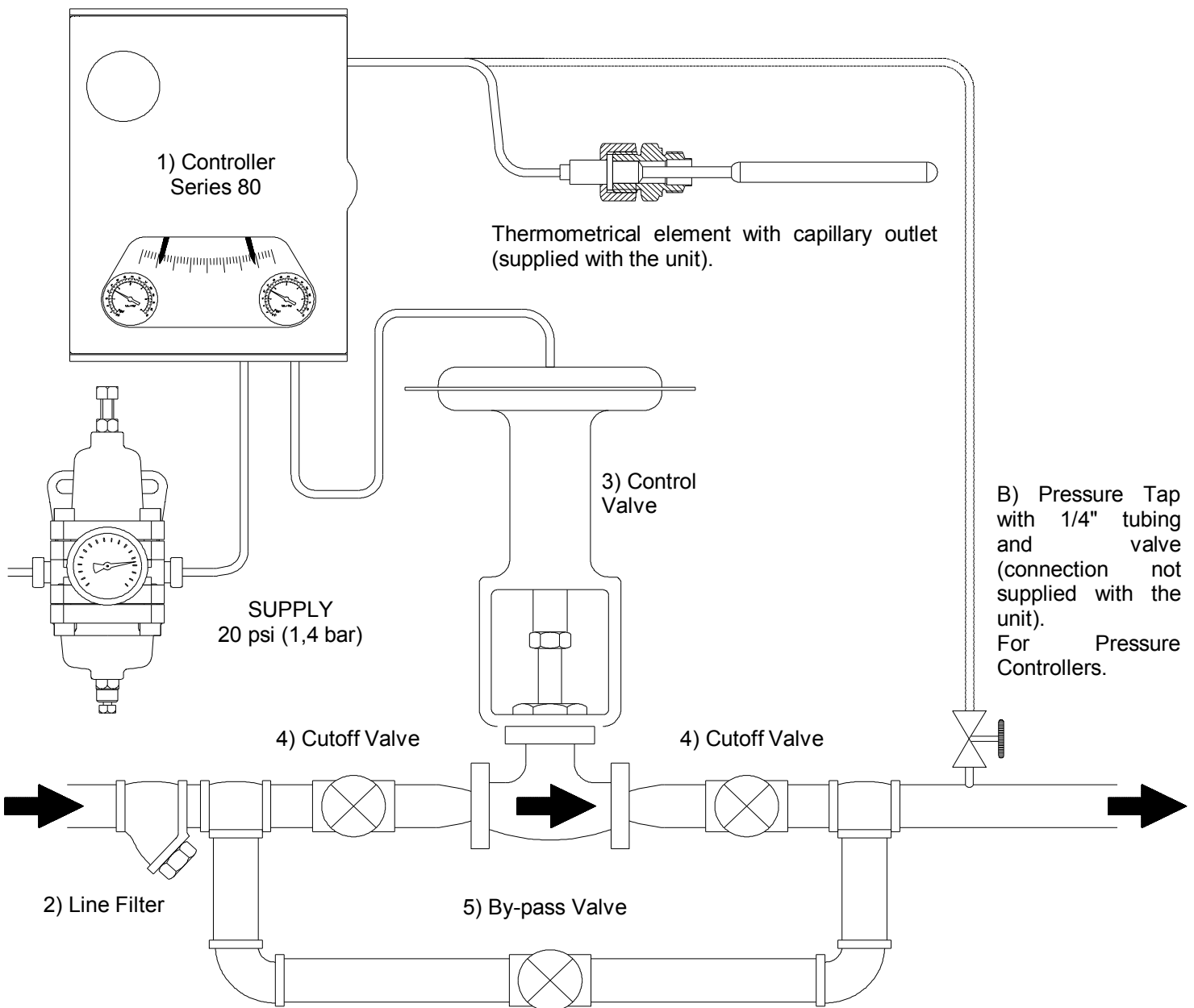

Fig. 2.2.1 "PNEUMATIC CONTROL VALVE INSTALLATION"

2.3. AUTOMATIC/MANUAL SELECTION PANEL MOD.251 (Fig. 2.3.1 and 2.3.2)

Use the automatic/manual selection panel to override the automatic control system, to operate the system manually or when the control conditions are difficult. The control panel mod. 251 consists of a two-position switch (automatic and manual), a control knob and a pressure gauge that indicates the preset output signal. Before operating a control unit equipped with an automatic / manual selector panel, make certain that the operation procedure described in paragraph 3 has been fulfilled.

A - Turn the selector on manual (M).

B - Close the pneumatic control valve by turning the control knob.

C - Completely open the cutoff valves situated upstream and downstream to the control valve. Make sure that the bypass valve is closed (see Fig. 2.2.1).

D - By turning the control knob, gradually open the pneumatic valve until the black indicator of the controller coincides with the red indicator.

E - Turn the selector on automatic (A).

The automatic/manual selector panel mod. 251 is used to shift from the automatic to the manual operation. To perform this operation, the pneumatic output signal and the control signal (indicated by the output pressure gauge) must be under equal pressure. Turn the selector on the left on manual (M).

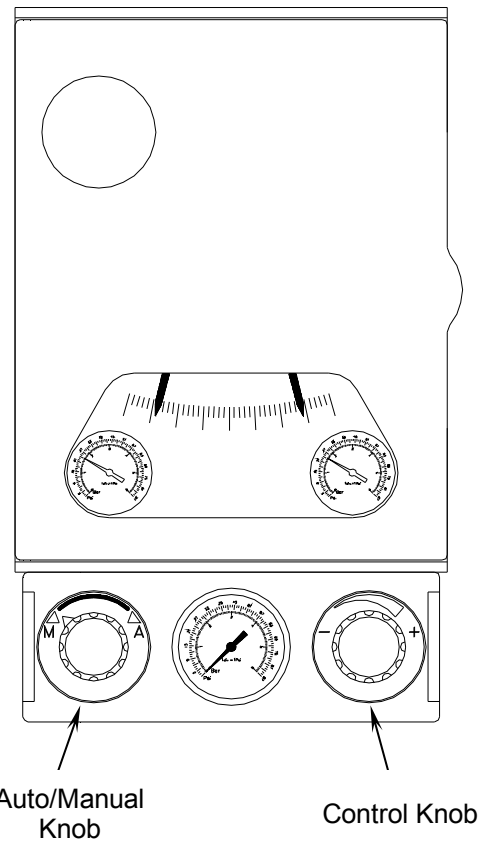

Fig. 2.3.1 " CONTROLLER WITH AUTO/MANUAL SELECTION PANEL"

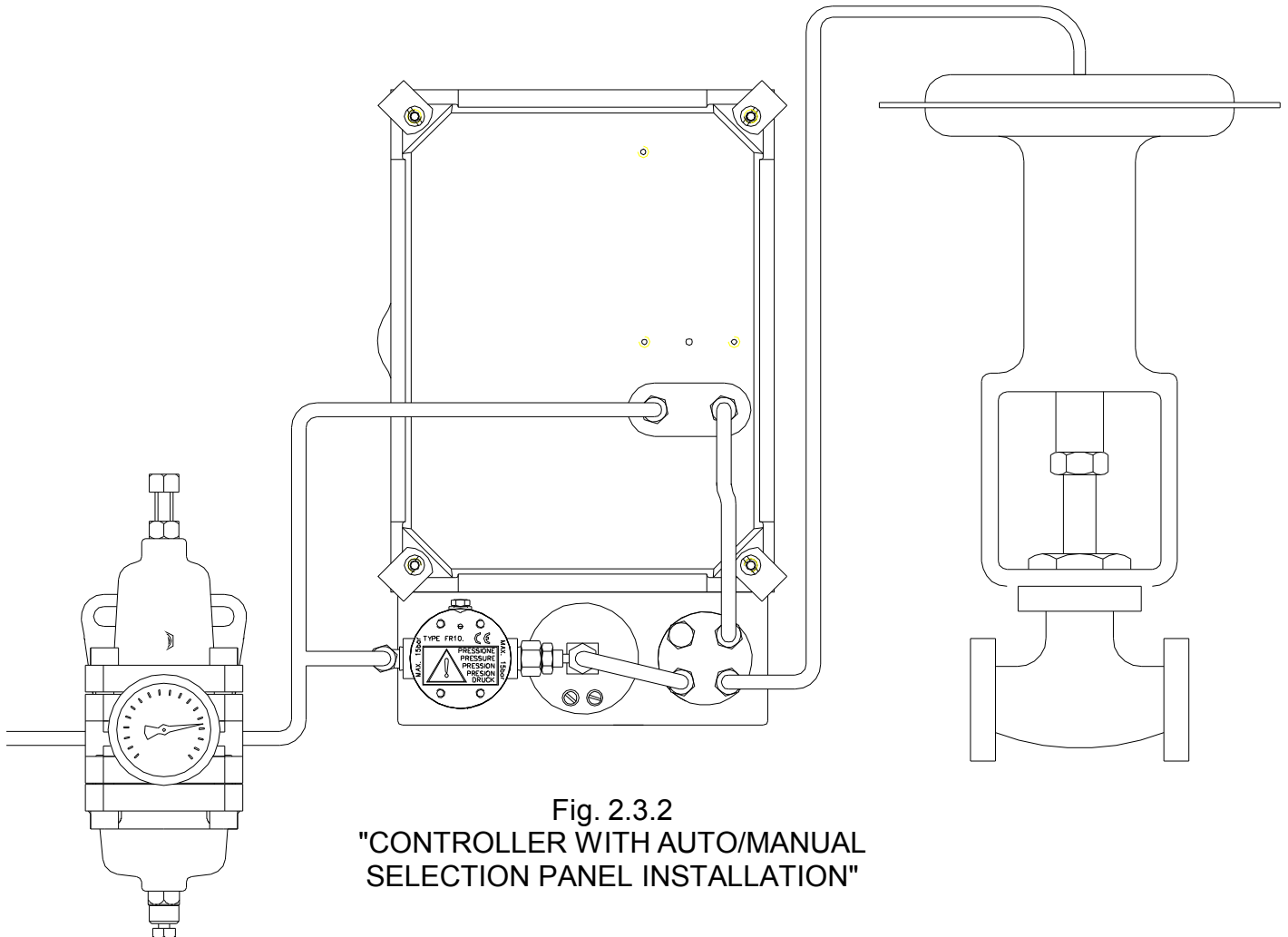

Fig. 2.3.2
"CONTROLLER WITH AUTO/MANUAL SELECTION PANEL INSTALLATION"

3. OPERATION

If the control unit is provided with an auto/manual selection panel, set the selector on automatic.

3.1. CONTROLLER ON-OFF (Fig. 3.1.1)

A - Apply a 20 psi air supply (± 1.5) and open the bleed valve of the pressure reducer filter (see Fig. 2.1.1) until any condensate has been completely discharged.

B - Use the set point knob (25) to adjust the red indicator (22) to the set point.

C - Rotate the knob (10) to adjust the proportional band to a 0% width and check the selected action of the instrument (DIRECT= the output signal increases as the variable increases; REVERSE= the output signal increases as the variable decreases).

D - Make sure that the bypass valve (5) supplied with the pneumatic valve (3) is completely closed and that the downstream cutoff valve (4) is fully open (see Fig. 2.2.1).

E - Open the cutoff valve (4) situated upstream to the pneumatic valve slowly and completely (see Fig. 2.2.1).

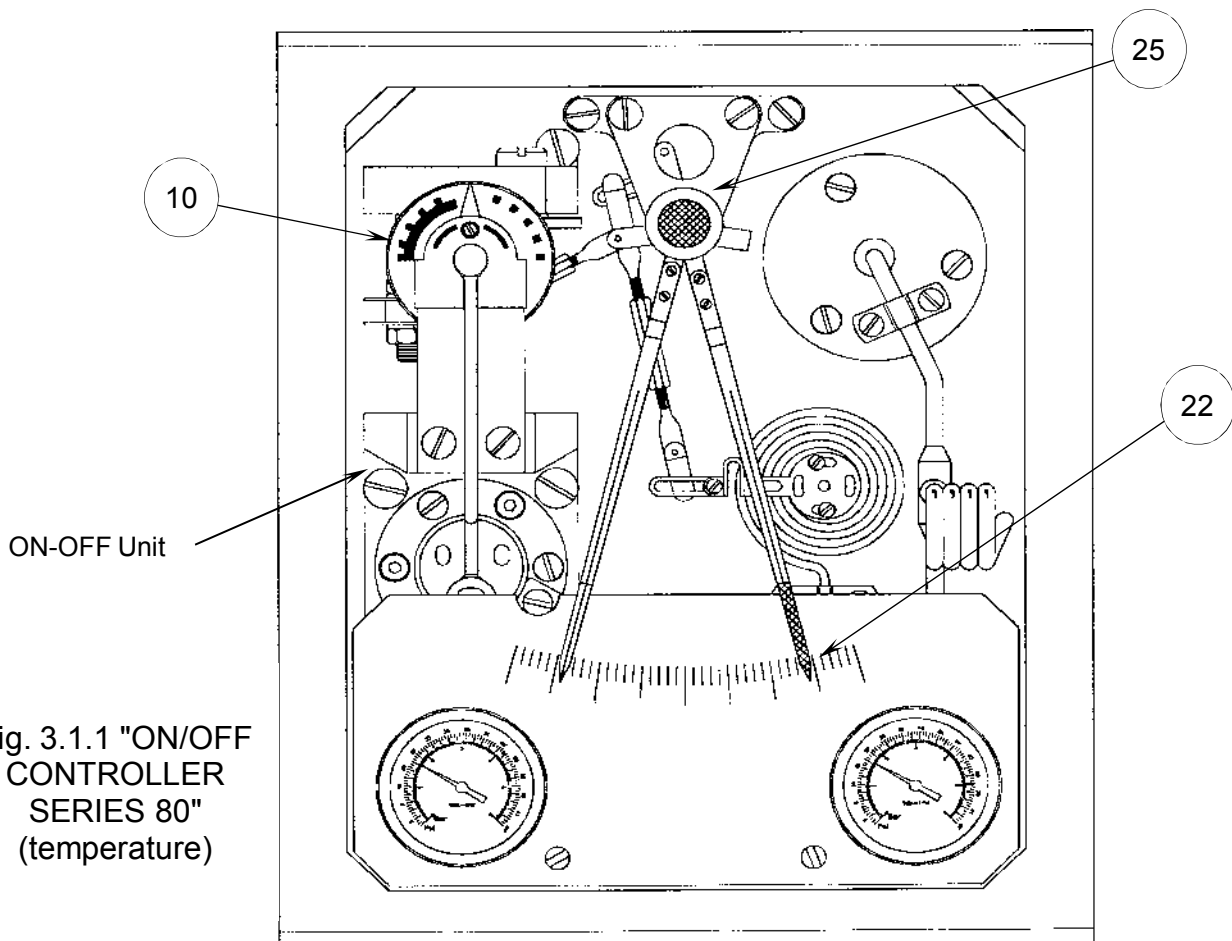

Fig. 3.1.1 "ON/OFF
CONTROLLER
SERIES 80"
(temperature)

3.2. PROPORTIONAL CONTROLLER (P) (Fig. 3.2.1)

A - Apply a 20 psi air supply (± 1.5) and open the bleed valve of the pressure reducer filter (see Fig. 2.1.1) until any condensate has been completely discharged.

B - Use the set point knob (25) to adjust the red indicator (22) to the set point.

C - Rotate the knob (10) to adjust the proportional band to a 20% width and check the selected action of the instrument (DIRECT= the output signal increases as the variable increases; REVERSE= the output signal increases as the variable decreases).

D - Make sure that the bypass valve (5) supplied with the pneumatic valve (3) is completely closed and that the downstream cutoff valve (4) is fully open (see Fig. 2.2.1).

E - Open the cutoff valve (4) situated upstream to the pneumatic valve slowly and completely (see Fig. 2.2.1).

F - If the control setting tends to fluctuate and the black indicator constantly oscillates towards the red indicator, gradually increase the width of the proportional band until stability is restored.

G - To make certain that the proportional band value is appropriate, initiate a deliberate disruption by rapidly moving the red indicator from the setpoint. If oscillation occurs again, slightly widen the proportional band and repeat the operation until stability is restored. The best control is obtained with the narrowest proportional band, which is compatible with the stability of the process at the various loads.

H - The black indicator may not coincide with the red indicator at the setpoint. To eliminate the difference, slightly turn the manual reset knob (14).

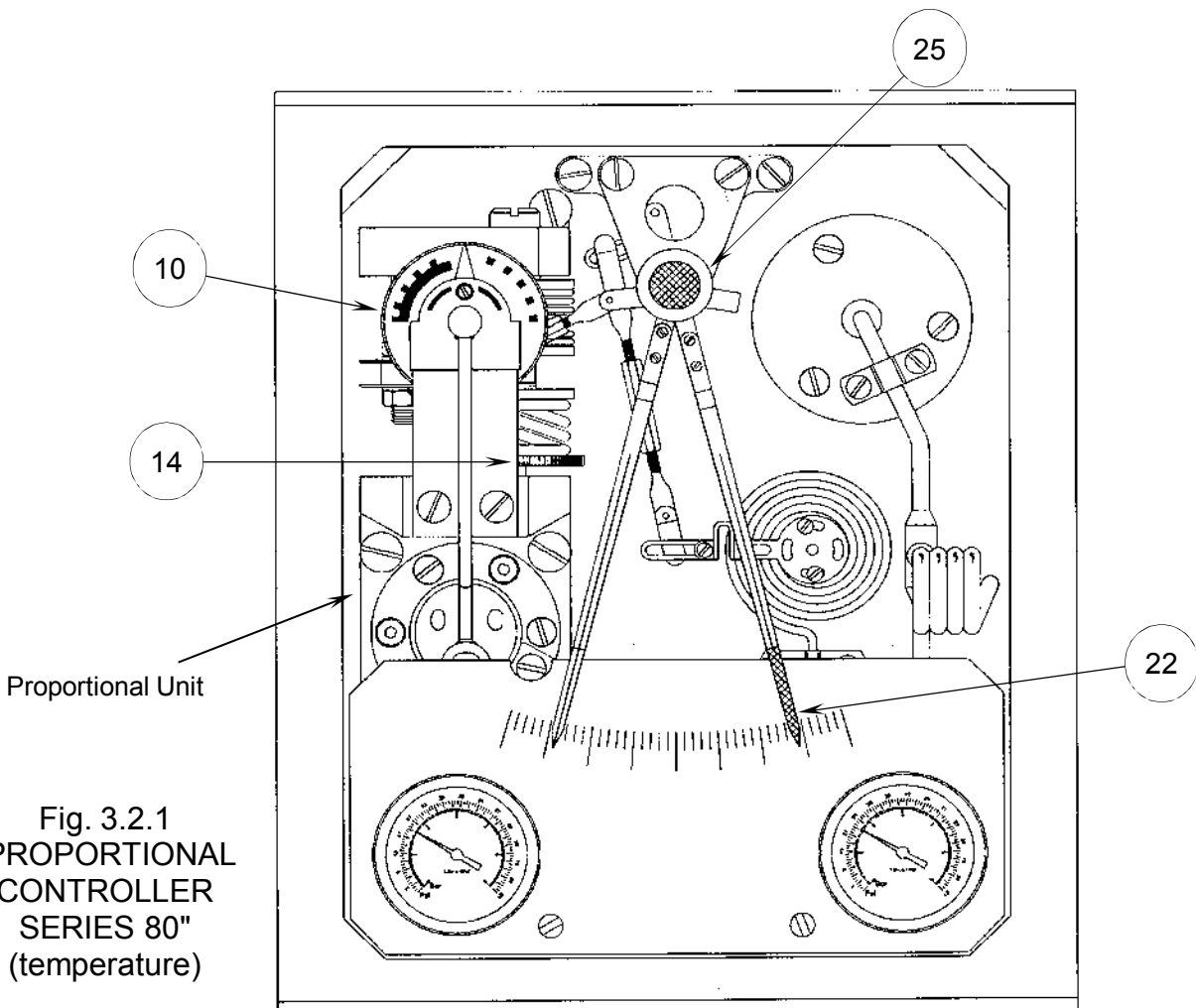

Fig. 3.2.1
"PROPORTIONAL
CONTROLLER
SERIES 80"
(temperature)

3.3. PROPORTIONAL + INTEGRAL CONTROLLER (P+I) (Fig. 3.3.1)

A - Apply a 20 psi air supply (± 1.5) and open the bleed valve of the pressure reducer filter (see Fig. 2.1.1) until any condensate has been completely discharged.

B - Open the integral action valve by rotating the knob (48) clockwise. Move the red indicator by rotating the set-point knob (25) to set the output signal manometer (21) to 9 psi. Completely close the valve by rotating the knob (48) counterclockwise to the lock.

C - Use the set point knob (25) to adjust the red indicator (22) to the setpoint.

D - Rotate the knob (10) to adjust the proportional band to a 20% width and check the selected action of the instrument (DIRECT= the output signal increases as the variable increases; REVERSE= the output signal increases as the variable decreases).

E - Make sure that the bypass valve (5) supplied with the pneumatic valve (3) is completely closed and that the downstream cutoff valve (4) is fully open (see Fig. 2.2.1).

F - Open the cutoff valve (4) situated upstream to the pneumatic valve slowly and completely (see Fig. 2.2.1).

G - If the control setting tends to fluctuate and the black indicator constantly oscillates towards the red indicator, gradually increase the width of the proportional band until stability is restored.

H - To make certain that the proportional band value is appropriate, initiate a deliberate disruption by rapidly moving the red indicator from the setpoint. If oscillation occurs again, slightly widen the proportional band and repeat the operation until stability is restored. The best control is obtained with the narrowest proportional band, which is compatible with the stability of the process at the various loads.

I - The black indicator may not coincide with the red indicator at the setpoint. To eliminate the difference, gradually open the integral action valve until the indicators coincide and initiate a deliberate disruption by rapidly moving the red indicator from the setpoint. If the black indicator starts fluctuating, slowly close the valve (48) until stability is restored and the indicators coincide. Initiate a new disruption and check the fluctuation of the black indicator. Turn the knob (48) again, if necessary.

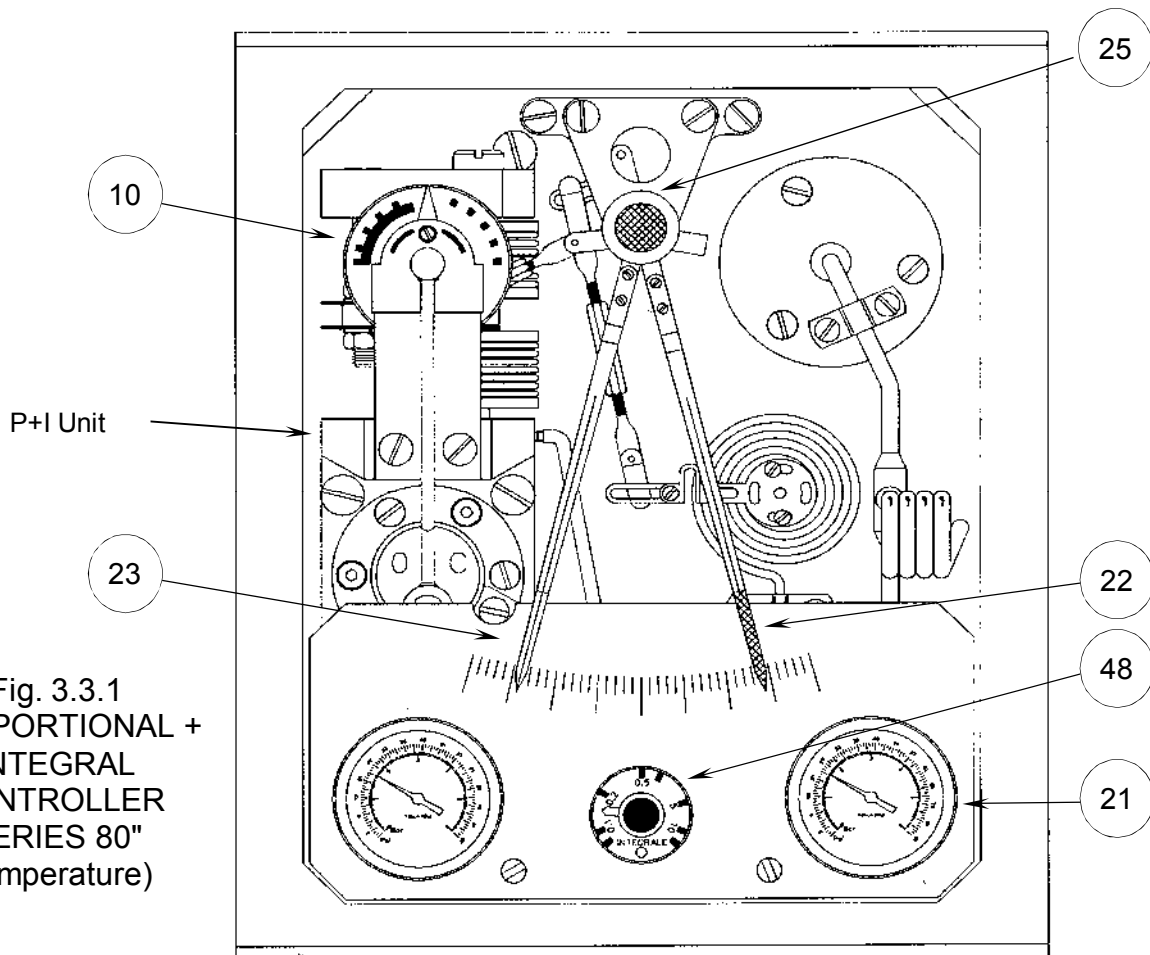

Fig. 3.3.1
"PROPORTIONAL +
INTEGRAL
CONTROLLER
SERIES 80"
(temperature)

3.4. PROPORTIONAL + INTEGRAL + DERIVATIVE CONTROLLER (P+I+D) (Fig. 3.4.1)

A - Open the derivative action valve by rotating clockwise the knob (53) to the lock.

B - Apply a 20 psi air supply (± 1.5) and open the bleed valve of the pressure reducer filter (see Fig. 2.1.1) until any condensate has been completely discharged.

C - Open the integral action valve by rotating the knob (48) clockwise. Move the red indicator (22) by rotating the set-point knob (25) to adjust the output signal manometer (21) to 9 psi. Completely close the valve by rotating counterclockwise the knob (48) to the lock.

D - Use the set point knob (25) to adjust the red indicator (22) to the setpoint.

E - Rotate the knob (10) to adjust the proportional band to a 20% width and check the selected action of the instrument (DIRECT= the output signal increases as the variable increases; REVERSE= the output signal increases as the variable decreases).

F - Make sure that the bypass valve (5) supplied with the pneumatic valve (3) is completely closed and that the downstream cutoff valve (4) is fully open (see Fig. 2.2.1).

G - Open the cutoff valve (4) situated upstream to the pneumatic valve slowly and completely (see Fig. 2.2.1).

H - If the control setting tends to fluctuate and the black indicator constantly oscillates towards the red indicator, gradually increase the width of the proportional band until stability is restored.

I - To make certain that the proportional band value is appropriate, initiate a deliberate disruption by rapidly moving the red indicator from the setpoint. If oscillation occurs again, slightly widen the proportional band and repeat the operation until stability is restored. The best control is obtained with the narrowest proportional band, which is compatible with the stability of the process at the various loads.

L - The black indicator may not coincide with the red indicator at the setpoint. To eliminate the difference, gradually open the valve (48) until the indicators coincide and initiate a deliberate disruption by rapidly moving the red indicator from the setpoint. If the black indicator starts fluctuating, slowly close the valve by turning the knob (48) until stability is restored and the indicators coincide. Initiate a new disruption and check the fluctuation of the black indicator: if necessary, adjust the valve again by turning the knob (48). Perform the adjustment one more time. If, during the adjustment, the manometer (21) indicates values inferior to 4 psi or superior to 12 psi, gradually close the derivative action valve by rotating the knob (53) until the reading of the manometer during the adjustment operation is $4 \div 12$ psi.

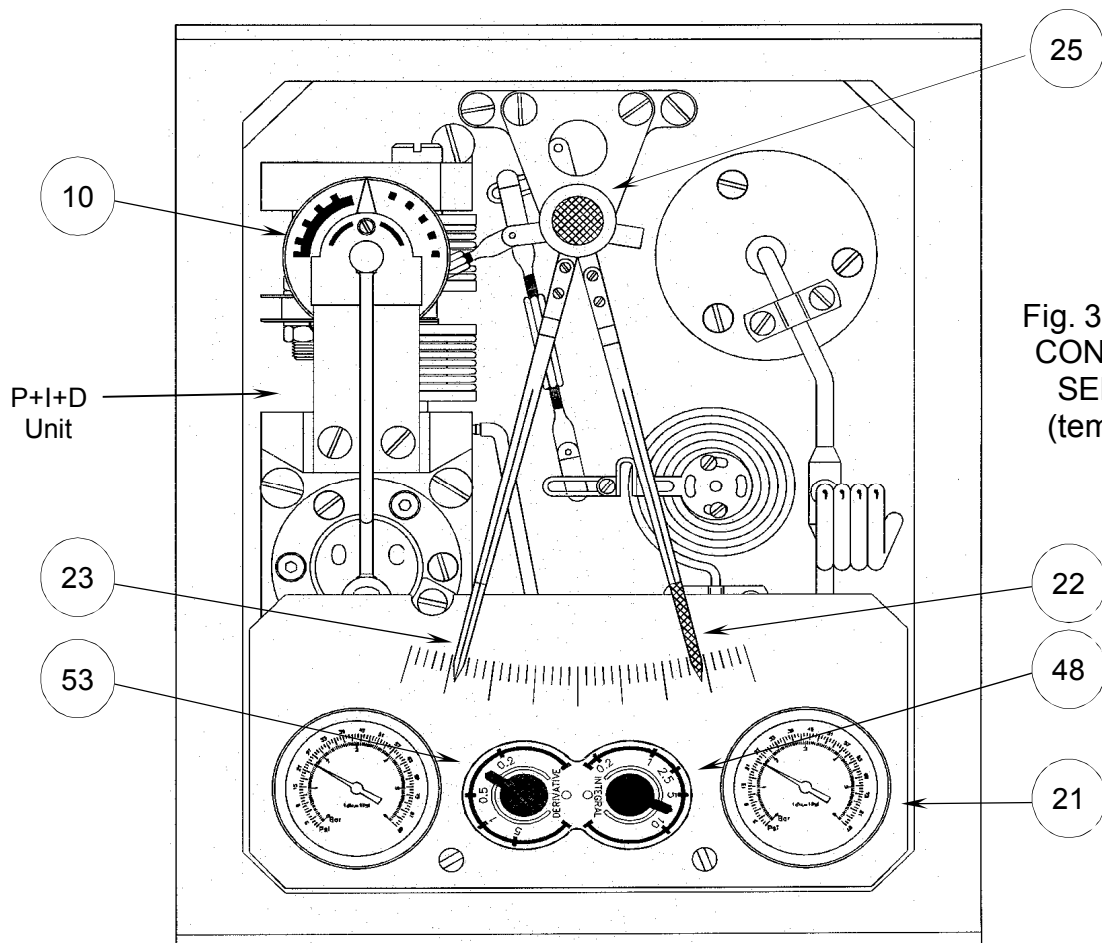

Fig. 3.4.1 "P+I+D
CONTROLLER
SERIES 80"
(temperature)

3.5 TRANSMITTER OPERATION

A - Apply a 20 psi air supply (± 1.5) and open the bleed valve of the pressure reducer filter (see Fig. 2.1.1) until any condensate has been completely discharged.

4. MAINTENANCE

Follow the instructions indicated below for routine maintenance of the control unit:

- 1) Daily bleed the filter in the air supply line until any water, air or other impurities are completely expelled.
- 2) Keep the pneumatic control valve in good operating conditions, so as to avoid any friction or wear which might interfere with proper control operation.

5. TROUBLE CHART: SYMPTOMS, CAUSES AND ACTION TO TAKE

Before operating the unit, please check:

- the unit proper supply
- the pneumatic and process connections
- the good operating conditions and status of the control valve

SYMPTOM	CAUSE	ACTION TO TAKE
Control action minimal or not present, output pressure steadily low or non-existent.	Wrong direction of control action	Correct. See paragraph 3
	Relay nozzle obstructed	Clean. See paragraph 6.1
	Pneumatic relay dirty	Clean. See paragraph 6.3
	Control valve diaphragm damaged	Inspect and replace the diaphragm, if necessary
The control variable doesn't coincide with the setpoint (OFF-SET)	Air leaks in the control signal line	Detect and eliminate the air leak
	Proportional band too wide	Decrease. See paragraph 3
	Low integral action speed (controller P+I and P+I+D)	Increase the number of repetitions per minute. See paragraph 3.3
	Integral action tap damaged (controller P+I and P+I+D)	Replace the tap
	Relay nozzle partially obstructed	Clean. See paragraph 6.1
Output signal steadily high, notwithstanding the position of the black and red indicators	Nozzle obstructed or dirty	Clean. See paragraph 6.2
	Loss in the relay nozzle due to the O-Rings	Replace the O-Rings. See paragraph 6.1
	Pneumatic relay dirty	Clean. See paragraph 6.3
	Relay diaphragms damaged	Replace the diaphragms. See paragraph 6.3
The control variable indicator fluctuates. Stability cannot be restored	Proportional band or integral action values wrong	Correct. See paragraph 3
	Friction in the control valve	Inspection and maintenance
	Control valve oversized	Check the size according to the operating conditions
The black indicator tends to settle on high/low values, notwithstanding the position of the setpoint indicator	Derivative action value wrong (controller P+I+D)	Correct. See paragraph 3.4
	Derivative action tap damaged (controller P+I+D)	Replace the tap
The control point varies by changing the proportional band width	Pneumatic relay dirty	Clean. See paragraph 6.3
	Relay diaphragms damaged	Replace the diaphragms. See paragraph 6.3
	Control unit not aligned	Align. See paragraph 8
The black indicator of the control variable shows a deviation from the real value superior to 1%	Measuring element not zeroed	Perform the zero-setting. See paragraph 7

6. CONTROLLER CLEANING

6.1 RELAY NOZZLE CLEANING

Remove the screw (13) (see Fig. 6.1.1) and clean, as shown in Fig. 6.1.2, by means of the supplied steel wire situated inside the instrument. If the capillary orifice is obstructed, clean it with a bath in trichloroethylene and a blow of compressed air. Before fastening the screw (13), we recommend lubricating the O-rings by applying a coat of silicone lubricant.

6.2 FLAPPER-NOZZLE UNIT CLEANING

Unscrew the screw (8) (see Fig. 6.1.1). Remove the dial (54), the tube (9) and clean, as shown in Fig. 6.2.2, by means of the supplied steel wire situated inside the instrument. During this operation keep the oscillating plate away from the nozzle, to avoid scratching it. Before mounting the tube (9), we recommend lubricating the O-rings by applying a coat of silicone lubricant.

WARNING TIGHT THE SCREW "13" LIGHTLY

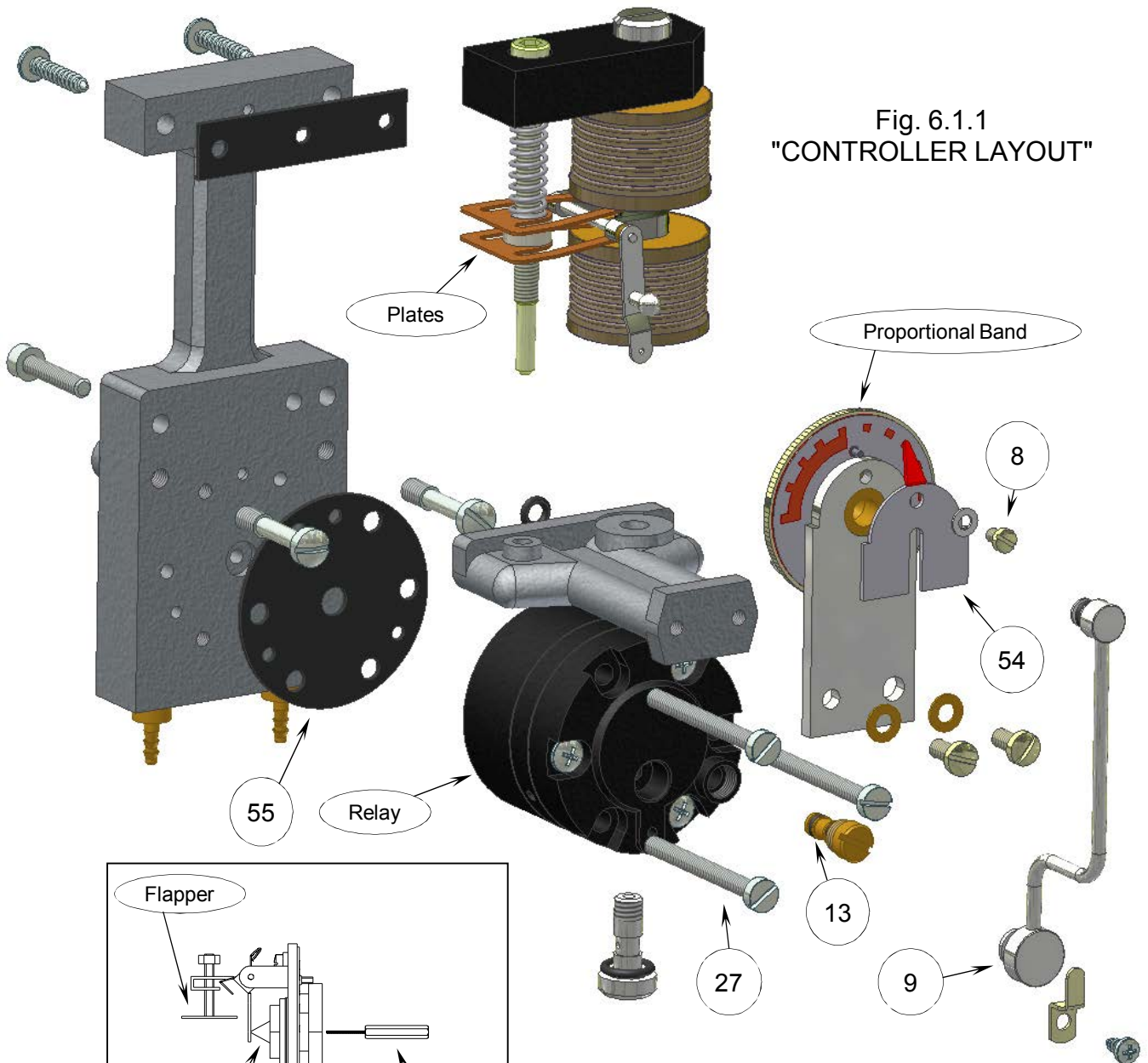
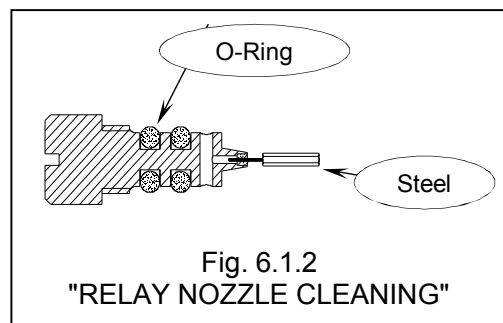
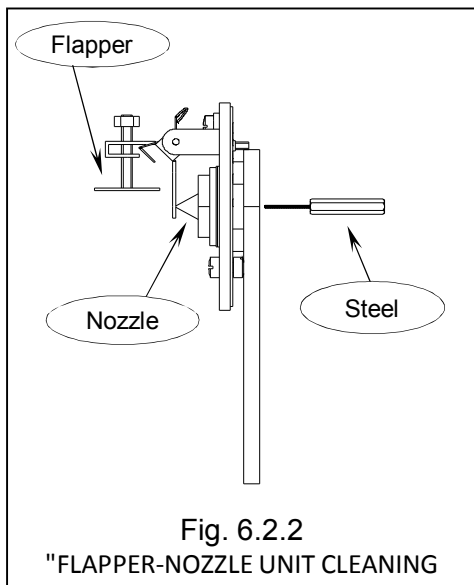

Fig. 6.1.1
"CONTROLLER LAYOUT"



6.3 RELAY CLEANING

If there is any oil and condensate in the air supply, clean the diaphragms (31) and (35) and the other inside elements of the relay (see Fig. 6.3.2). Disassemble the relay as follows:

- 1) Loosen the tube fastening plate to the relay (9) (see Fig. 6.3.1).
- 2) Remove the bottom connection of the tube (9) (see Fig. 6.3.1).
- 3) Remove the three fastening screws (27) and extract the relay (see Fig. 6.3.1).
- 4) Remove the three Allen screws (28) and disassemble the relay (see Fig. 6.3.2). Clean or replace the diaphragms.
- 5) Assemble the relay. Follow the layout drawing shown in Fig. 6.3.2.

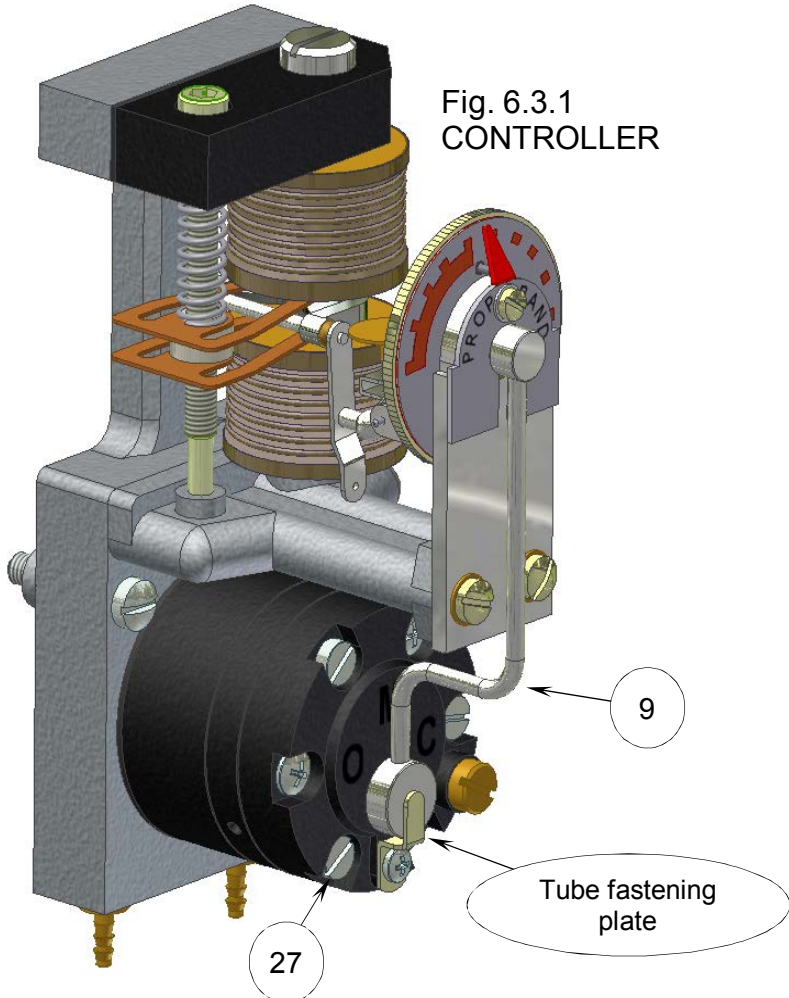

"ELEMENTS (32) AND (35) ASSEMBLY"

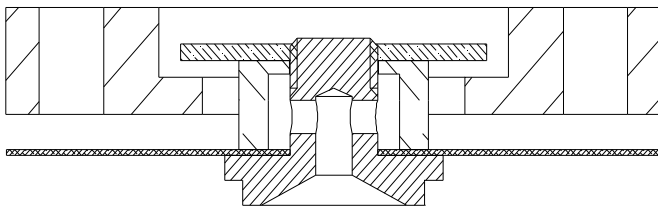

Fig. 6.3.4

"ELEMENTS (38), (39) AND (41) ASSEMBLY"

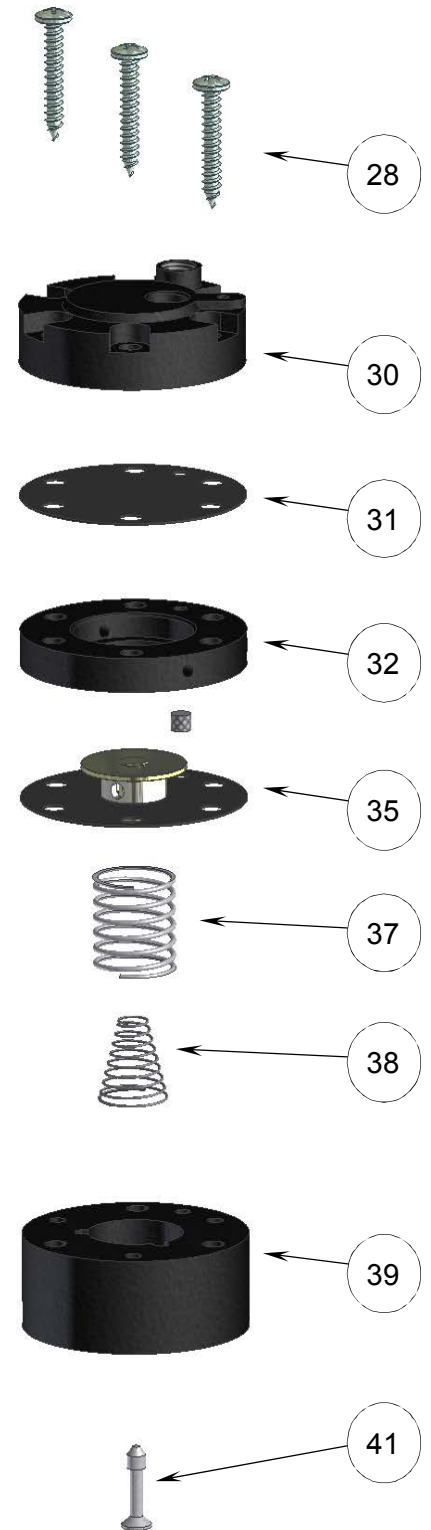
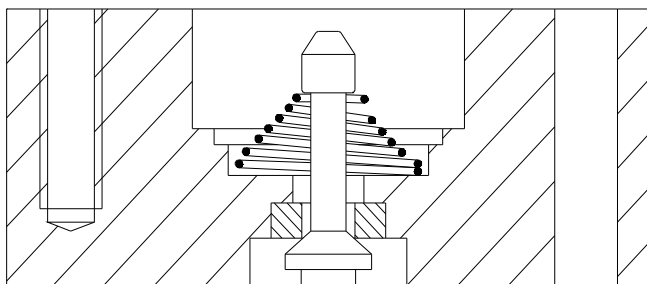

Fig. 6.3.2
"RELAY LAYOUT"

7. MEASURING ELEMENT ZERO SETTING

Correct any minimal deviations of the black indicator (measured variable) from the real value by turning the hexagonal part of the tie rod (45) (see Fig 8.1.1 and 8.1.2).

8. CALIBRATION

THE FOLLOWING CALIBRATION PROCEDURE IS TO BE PERFORMED BY AUTHORIZED PERSONNEL ONLY

8.1 SENSITIVE ELEMENT CALIBRATION

The calibration of the instrument is possible by performing three combined standard calibration procedures. They are:

- Zero adjustment; it moves the whole scale of the same quantity
- Range adjustment; it increases or decreases the full scale value
- Linearity adjustment; it changes the linearity of the instrument

This procedure is based on the scale values: 0%, 50% and 100%. If a temperature measuring element is provided with the unit, use 20% instead of 0% and 80% instead of 100%.

See Fig. 8.1.1 for temperature and pressure elements. See Fig. 8.1.2 for 3÷15 psi receiving elements.

ZERO ADJUSTMENT

1) Apply 0% of control variable: the black indicator reads 0% \pm 1% of full scale.

2) If not, adjust the tie rod (45) until 0% \pm 1% of full scale is obtained.

RANGE ADJUSTMENT

1) Apply 100% of control variable: the black indicator reads 100% \pm 1% of full scale.

2) If not, slide the plate "C" by unscrewing the corresponding screws and set the black indicator to a value equal and opposite to the exceeding value.

3) Repeat the zero adjustment.

4) Repeat the range calibration procedure until the required reading is obtained.

LINEARITY ADJUSTMENT

1) Apply 50% of control variable: if the black indicator reads 50% \pm 1% of full scale, the calibration procedure is complete.

2) If not, adjust linearity by varying the rotatory angle of the linkage arm (51) by means of the corresponding screws. Turn the linkage arm clockwise if the reading is superior to the required value and vice versa.

3) Repeat the zero, range and linearity adjustment procedure until the required values are obtained.

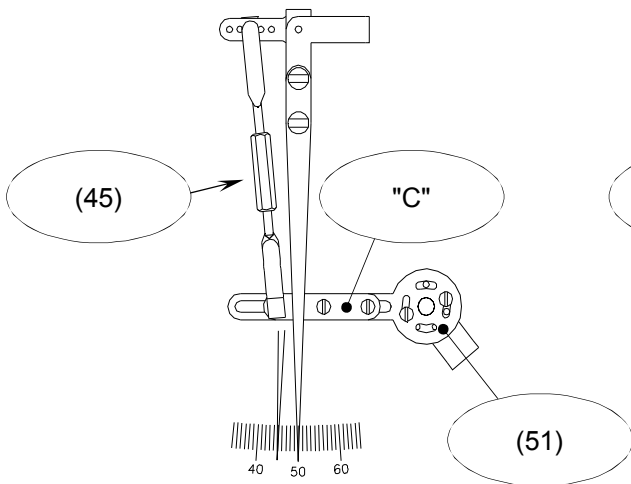

Fig. 8.1.1

"MANOMETRIC AND THERMOMETRIC

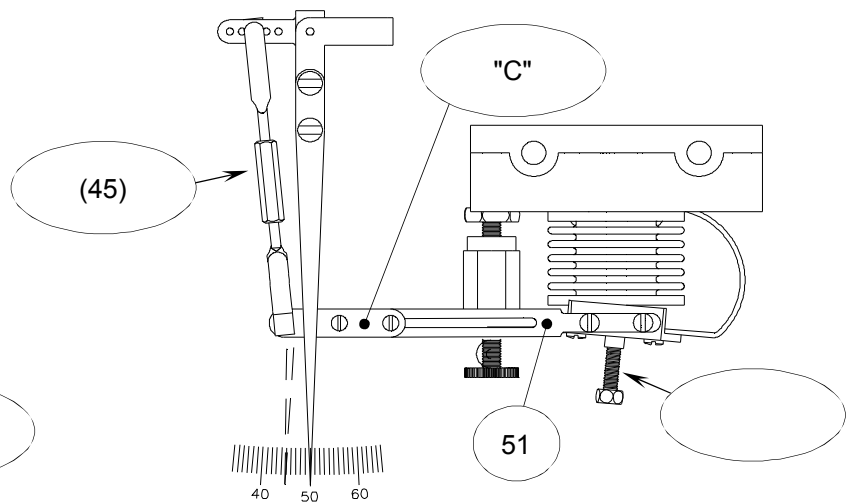

Fig. 8.1.2

"RECEIVING ELEMENT 3÷15 psi"

8.2 CONTROL UNIT ALIGNMENT (Fig. 8.2)

- 1) Disconnect the tie rod (45) from position "A".
 - 2) Clip the red and black indicators together at any scale position.
 - 3) Apply a 20 psi air supply.
 - 4) Set the Proportional Band knob to the infinity position.
 - 5) Verify that the output is 9 psi. If not, (for Proportional Controllers only) turn the knob (14) until a 9 psi output is obtained (see Fig. 3.2.1). For P+I or P+I+D Controllers, obtain the same value by means of the tie rod (46).
 - 6) Turn the Proportional Band knob to 20% (reverse or direct).
 - 7) Turn the Proportional Band knob to a value equal and opposite to the value obtained at point 6. Make sure that the output is 9 psi.
- Note: If the output signal is different from 9 psi \pm 1, adjust the tie rod (46) (also for Proportional Controllers only).
- 8) Connect the tie rod (45) to position "A".

Fig. 8.2 "CONTROLLER"

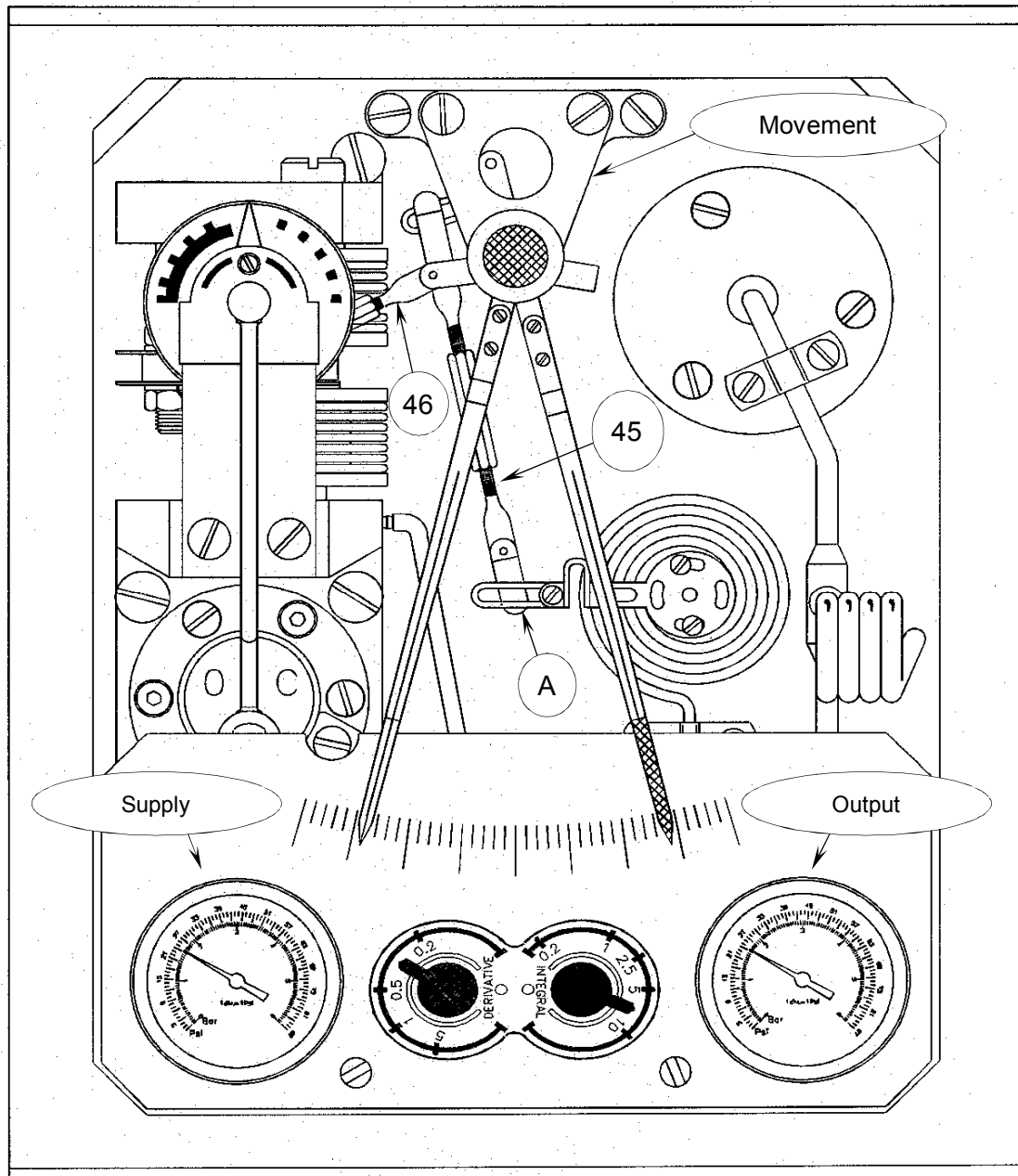

9. SPARE

DESCRIPTION	REFERENCE
ON-OFF Unit, manometers included	Fig. 3.1.1
PROPORTIONAL Unit 3 ÷ 15 psi, manometers included	Fig. 3.2.1
PROPORTIONAL Unit 6 ÷ 18 psi, manometers included	Fig. 3.2.1
PROPORTIONAL Unit 6 ÷ 30 psi, manometers included	Fig. 3.2.1
P+I Unit, manometers and tap included	Fig. 3.3.1
P+I+D Unit, manometers and taps included	Fig. 3.4.1
TRANSMITTER Unit, manometers included	
Relay	Fig. 6.1.1
Set relay diaphragms	(55) Fig. 6.1.1 / (31) and (35) Fig. 6.3.2
Complete proportional band Unit	Fig. 6.1.1
Relay connection tie rod	(46) Fig. 8.2
Sensitive element connection tie rod	(45) Fig. 8.2
Nozzle, O-Ring included	Fig. 6.1.2
Movement, Set-Point included	Fig. 8.2
Steel wire	Fig. 6.1.2
Set-point or measure indicator	(22) and (23) Fig. 3.4.1
Control unit plates	Fig. 6.1.1
O-Ring set	Tubing and nozzle Fig. 6.1.1
Standard Dial	Fig. 3.1.1
Special-purpose Dial	Fig. 3.1.1
Standard Dial P+I	Fig. 3.3.1
Special-purpose Dial P+I	Fig. 3.3.1
Standard Dial P+I+D	Fig. 3.4.1
Special-purpose Dial P+I+D	Fig. 3.4.1
Manometer Ø 40 supply / output 35 psi / 2.5 bar	Manometers Fig. 8.2
INTEGRAL action Tap	(48) Fig. 3.3.1
INTEGRAL + DERIVATIVE action Tap (not separately)	(48) and (53) Fig. 3.4.1

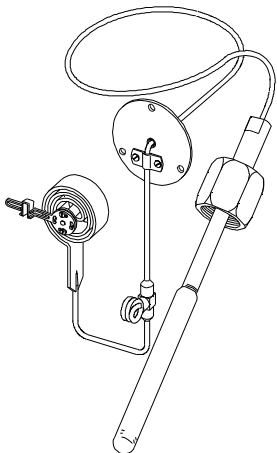

Complete Temperature Element

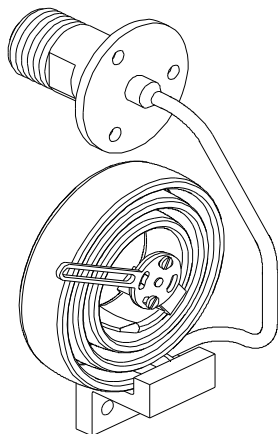

Complete Pressure Element

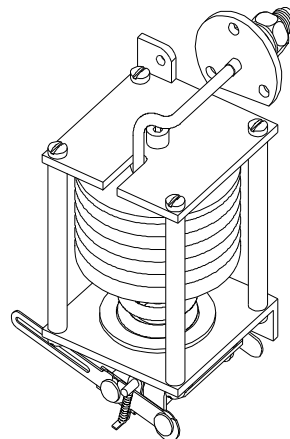

Complete Low Pressure Element

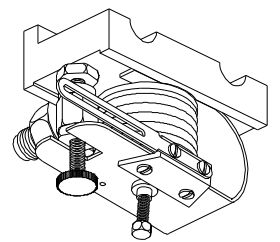

Complete Receiving Element 3÷15 psi

10. OVERALL DIMENSIONS

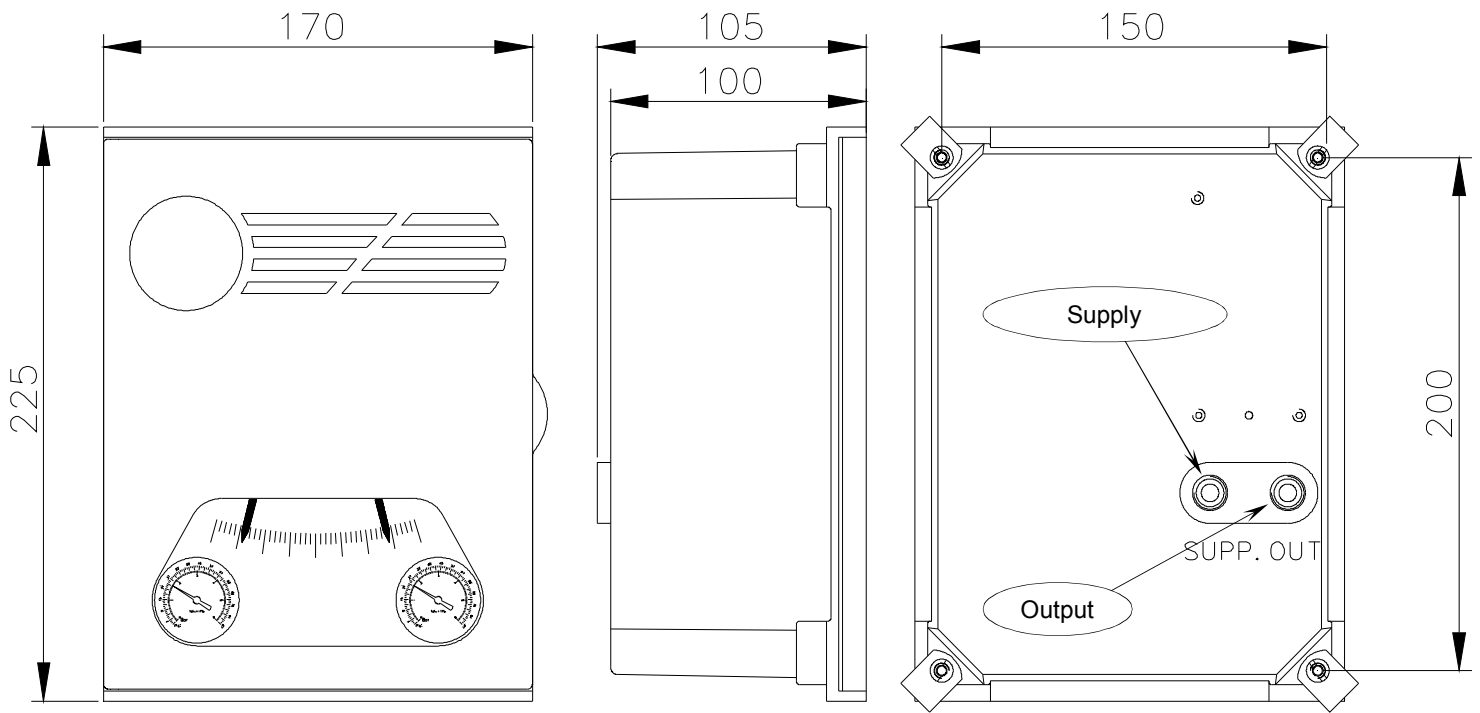

11. TECHNICAL DATA

Mounting	Wall or Panel	
Pneumatic Connections	1/4" NPT	
Air Supply	20±1.5 psi / 1.4 ± 0.1 bar	35 ± 1.5 psi / 2.4 ± 0.1 bar
Output	3÷15 psi / 0.2÷1 bar	6÷30 psi / 0.4÷2 bar
Proportional action	Proportional Band endless ±200%	
Integral action	>0...>10 rep./min.	
Derivative action	0...>5 min. rep.	
Steady State Air Consumption	Air Supply 20 psi / 1.4 bar 0.13 Nm³/h	
Air Delivery	2.6 Nm³/h	
Accuracy	≤ 1%	
Hysteresis	≤ 0.5%	
Linearity	≤ 0.5%	
Repeatability	≤ 0.5%	
Room Temperature Limit	-20....+ 80 °C	
Weight	~3 Kg	